

OBSERVATOIRE DE PARIS
INSTITUT DE MÉCANIQUE CÉLESTE ET DE CALCUL DES
ÉPHÉMÉRIDES
ED 127

THÈSE DE DOCTORAT
SPÉCIALITÉ MATHÉMATIQUES

par

Jessica Elisa MASSETTI

**QUASI-PÉRIODICITÉ ET
QUASI-CONSERVATIVITÉ**

sous la direction de

Alain CHENCINER and Jacques FÉJOZ

Thèse soutenue le 23 octobre 2015 devant le jury composé de :

M. Alain CHENCINER	Université Paris-Diderot & Observatoire de Paris
M. Luigi CHIERCHIA	Università Roma Tre
M. Bassam FAYAD	Université Paris-Diderot
M. Jacques FÉJOZ	Université Paris-Dauphine & Observatoire de Paris
M. Jacques LASKAR	Observatoire de Paris
M. Jean-Pierre MARCO	Université Pierre et Marie Curie

D'après les rapports de:

M. Luigi CHIERCHIA	Università Roma Tre
M. Jean-Pierre MARCO	Université Pierre et Marie Curie

Ad Happy (Allegra) Magenta

Arbusta iuvant humilesque Myricae

Contents

Merci	v
Nomenclature	xi
Introduction	xiii
From the normal form of Moser...	xiv
...to other normal forms	xvi
Invariant tori: elimination of parameters	xvii
The spin-orbit problem	xviii
The parameter space of the spin-orbit problem	xix
Chapter 1. The normal form of Moser	1
1.1. Overview	1
1.2. Functional setting	4
1.2.1. Complex extensions	5
1.2.2. Space of conjugacies	6
1.2.3. Spaces of vector fields	7
1.2.4. The normal form operator ϕ	8
1.2.5. Cohomological equations	8
1.3. Estimates on ϕ'^{-1} and ϕ''	12
1.3.1. Second derivative	16
1.4. The abstract inverse function theorem	17
1.5. Proof of Moser's theorem	22
Chapter 2. Normal forms for some class of dissipative systems	25
2.1. Hamiltonian systems: Herman's theorem	25
2.1.1. Notations & objects	26
2.2. Hamiltonian + dissipation: "dissipative Herman" theorem	28
2.2.1. Spaces of vector fields	28
2.2.2. Spaces of conjugacies	28
2.2.3. The linearized problem	30
2.3. A first portrait	32
A first diagram of dissipative systems	32
2.4. Normal form "à la Rüssmann"	33
2.4.1. A parametrization from Celestial Mechanics	33

2.4.2.	A translated torus theorem	37
2.4.3.	Second portrait	39
Chapter 3.	Invariant tori	41
3.1.	First application: Spin-orbit in n d.o.f.	42
3.1.1.	Normal form & elimination of b	42
3.2.	Spin-Orbit problem of Celestial Mechanics	44
3.2.1.	Extending the phase space	46
3.2.2.	A curve of invariant tori	48
3.3.	An important dichotomy	51
	First situation	52
	Second situation	53
Chapter 4.	The parameters' space of the spin-orbit problem: starting a global study	55
4.1.	Invariant circles of arbitrary rotation number	56
4.1.1.	The strength of dissipation: graph transform	57
4.2.	Second localization	61
4.2.1.	Towards another normal form	63
4.2.2.	Normally hyperbolic invariant circle, again	65
4.3.	Summary of the results	68
	Cantor set of curves	68
	Graph transforms 1&2	68
Appendix A.	A normal form theorem for diffeomorphisms in $\mathbb{T} \times \mathbb{R}$	71
A.1.	Outline of the proof	72
A.1.1.	Spaces of conjugacies	72
A.1.2.	The normal form operator	72
A.1.3.	Difference equation on the torus	73
A.1.4.	Inversion of ϕ' and bound of ϕ''	73
A.1.5.	Second derivative	76
A.1.6.	Final step	76
A.2.	The translated curve of Rüssmann	76
A.2.1.	Elimination of B	77
A.2.2.	A family of translated curves	78
A.2.3.	Torsion property: elimination of β	78
A.2.4.	Curves C_α for general perturbations of the unperturbed spin-orbit flow	79
Appendix B.	Hypothetical conjugacy and translated torus theorem	83
Appendix C.	Classical results	87
C.1.	Inversion of a holomorphism of \mathbb{T}_g^n	87

CONTENTS

iii

C.2. Calculus	89
Some useful derivations	89
Inverse mapping	89
Cotangent derivative	90
Push-forward of a vector field	90
Appendix D. Some inequalities	91
D.1. Cauchy's Inequality	91
D.2. Lie brackets of vector fields	91
Bibliography	93

Merci

Ce n'est pas pour me conformer à un rituel devenu pratiquement canonique que je me retrouve maintenant à écrire cette page d'ouverture. C'est plutôt un instinct que je ne veux (peux) pas contrôler. J'écris "merci", mais dedans se cache un monde.

Merci à mes directeurs de thèse Jacques Féjoz et Alain Chenciner, deux perles rares dans cette réalité où les statistiques prennent l'ascendant sur l'amour pour la science. Merci à Jacques pour m'avoir ouverte à la forme normale de Moser et insisté pour que je regardasse aux problèmes dans son état d'esprit - si conceptuellement beau. Sans ses conseils ce travail aurait manqué de cohérence et l'Annexe A, entre autres, aurait été beaucoup moins puissant. J'ai mis du temps à voir les choses mais là je les ressens toutes et je ne peux que lui être reconnaissante pour m'avoir accompagnée et appris autant. J'espère ne pas l'avoir trop déçu.

Merci à Alain pour la confiance, les conseils et la présence qu'il m'a toujours réservés. Si je doutais il était là, avec sa passion bouleversante à vouloir comprendre, réfléchir, aider. Son idée de peindre l'espace des paramètres du spin-orbite s'est révélée ambitieuse, étudier ses articles pour en comprendre les idées un peu "hard core", continuer ce que j'ai pu commencer au chapitre 4 sera une opportunité sans égal. Enfin, "Il faut toujours commencer par comprendre le cas le plus simple !", "attends, je ne vois plus rien re-explique moi" ou "tu écris comme un cochon" "tu parles trop" et encore "ah mais c'est ça que tu voulais dire ! D'accord, oui, mais ce n'est pas ce que tu as écrit ici !" : ta relecture de la thèse ne fut pas du tout une torture, au contraire un des moments les plus vifs (même drôles !) où j'ai appris énormément de maths (encore !) et, peut être, à écrire de façon "opportune" (?). Jacques, Alain, vous me pardonnerez les adjectifs présents dans cette page.

Merci à Jean-Pierre Marco et Luigi Chierchia qui ne m'ont pas seulement fait l'honneur d'être rapporteurs de cette thèse, mais aussi d'être vivement intéressés au sujet et de vouloir faire partie de mon jury. Raconter à Jean-Pierre où j'en étais au cours de ce travail m'a toujours rechargée et encouragée à continuer ; son dynamisme est précieux, j'ai hâte de pouvoir continuer nos discussions pour dissiper-diffuser ensemble.

Merci à Jacques Laskar pour sa soif de connaissance, pour son œil attentif et critique, pour son humour, pour sa curiosité polyédrique et son honnêteté intellectuelle. Il m'a toujours fait sentir son intérêt et son soutien, que ce soit pour ma recherche, mes candidatures, mes choix présents ou futurs. Ses remarques et conseils, scientifiques ou pas, n'ont jamais manqué d'importance. Je n'aurais pas imaginé - ni voulu! - autre président de jury que lui.

Merci à Bassam Fayad pour les après-midis passés ensemble à lui raconter de ma thèse et m'avoir toujours posé plein plein de questions lors que j'allais le voir pour...lui poser des questions. Les notes de Michael Herman qu'il m'a offertes ont été une étude clé pour certains résultats de cette thèse. C'est un plaisir et un honneur de l'avoir dans mon jury.

D'où commencer pour remercier mon équipe ? Car là, il ne s'agit pas de dire "merci car j'ai pu travailler dans des bonnes conditions" mais plutôt "merci, car je me sens faire partie d'une famille".

Merci à Thibaut Castan, pote de maths et pote tout court. Les milliers de discussion sur le KAM abstrait, le théorème d'inversion locale, les normes déformés, les formes normales de Birkhoff et plein d'autres choses encore m'ont apporté tellement. En plus, on a un théorème de fonction implicite super cool maintenant. Merci aussi parce que tu es toujours disponible quand je stresse, panique te propose de parler de maths, que ce soit au labo ou par téléphone. Et puis, aux finales de rugby on s'éclate bien!

Merci à Laurent Niederman pour m'écouter et m'aider à répondre à n'importe quelle question et à n'importe quelle heure au labo. Son "œil du tigre" et son franc parler sont toujours là quand je lui demande conseil. Merci aussi pour les weekends normands et les multiples dîners quand on fait tard, très tard, au labo.

Merci donc à Alain Albouy qui fait aussi partie des soirées-tard-au-labo mentionnées au dessus et qui, autre à être un remarquable mathématicien est d'une franchise rare (et ses blagues sont trop drôles).

Merci à Abed Bounemoura, pour son impulsivité quand il s'agit de résoudre un problème ou de réfléchir à une question et pour son altruisme mathématique et non.

Merci à Philippe Robutel, toujours au taquet pour réfléchir sur une question ou dissiper mes doutes en mécanique céleste ou en analyse élémentaire.

Merci à Hervé Manche, mon sage et cher copain de bureau, prêt à me dépanner quand je galère au PC, à passer des appels et à réfléchir avec moi sur toute question que je puisse lui poser et plein d'autre choses que je n'ai

pas assez d'espace pour mentionner. Ah oui, tes blagues macho et pseudo-morbides m'ont toujours mise de bonne humeur, même quand je n'allais pas bien.

Merci à Mickael Gastineau, car il a toujours du temps pour nous tous et je sais que je peux lui écrire n'importe quand et de n'importe où et en cinq minutes retrouver l'introuvable paquet \LaTeX directement installé sur ma machine.

Merci à Gwenael Boué et Nathan Hara, un binôme précieux quand on veut poser des questions et être sûr de ne pas dire de bêtises.

Merci à Adrien Leleu. Bien qu'il pense d'être mon "canard en plastique", ceci n'est pas vrai. Au contraire, j'ai toujours les réponses que je cherche (ou que je ne veux peut-être pas entendre) suite à nos conversations.

Comment oublier Farida ? Une vague de bonne humeur, franc parler, force, constance, culture, amitié, poésie.

Merci à Agnès Patu. Je n'ai jamais rencontré une secrétaire aussi disponible et amicale. Si j'ai besoin de quoi que ce soit, je sais pouvoir compter sur elle.

J'ai rencontré plein de chercheurs dans ces quatre ans, et chacun a eu son influence. Toutefois, je tiens en particulier à remercier Marc Chaperon, pour son calme et son être un interlocuteur attentif et posé. Il s'est toujours intéressé de l'évolution de ma thèse et montré disponible quand j'avais des questions ou cherchais des conseils.

Merci aussi à Laurent Stolovitch et Claire Chavaudret, pour m'avoir invitée à Nice à présenter mes travaux et en être sincèrement intéressés. J'espère un jour pouvoir vraiment travailler avec eux.

Grazie alla mia mamma e al mio papà. Per i sacrifici che hanno fatto e ancora fanno permettendomi di inseguire i sogni che voglio e che, in fondo, sono anche un po' loro. Credo che nessun papà chieda ogni giorno al proprio figlio di leggergli o fargli leggere la sua tesi e i suoi articoli, soprattutto se la materia in questione è lontana anni luce da quello che fa. Ma un giorno senza questa domanda è un giorno un po' vuoto, quindi aspetto sempre che me la faccia perché mi fa sentire importante, anche se non glielo dico mai. La mia mamma invece è sempre pronta a brandire la spada, montare sul treno e venir qui subito se avessi bisogno di aiuto. E poi la mamma è sempre la mamma, con le sue e t e r n e telefonate per raccontarmi qualsiasi cosa e assicurarsi che non mi perda niente, e soprattutto chiedermi mille cose, per assicurarsi che anche lei non si perda niente.

Grazie a mia sorella Frenky. Perché cerca sempre di tirarmi sù quando non sono in forma e vuol sempre sentire la mia opinione, anche se poi non corrisponde alle sue aspettative. Grazie anche per i suoi (eterni) racconti telefonici, che ascolto sempre con piacere e ravvivano la mia giornata. E'

stata la fonte di forza fondamentale (per me e non solo) di questi ultimi cinque anni. Ma questo, non glielo dico mai.

Grazie a mia nonna Enza, interlocutrice insostituibile, sempre sul pezzo quando si tratta dei miei seminari, concorsi, traguardi ed esperienze di ogni natura. E a mio nonno Tino, che è sempre stato qui intorno durante la redazione di queste sudate carte, e poi quel conto l'ha fatto tornare lui.

Grazie alla mia zia Moni e mio zio Angelo, che hanno sempre mostrato amore, comprensione, interesse e sostegno nelle mie scelte o nelle mie avventure di vita. E poi ci sono sempre.

Grazie anche a zio Albe, non solo perché ora ascolto musica decente mentre lavoro, ma anche perché so che è orgoglioso di avere una nipote che fa cose strambe e mi dice sempre che mi vuole bene.

Grazie a Miki, perché si dimentica che *non* sono sua sorella e quindi si comporta come tale nel bene e nel male, ma soprattutto nel bene. Grazie alla Mary #moderatrice, che quando sono a Milano viene sempre a trovarmi insieme a Miki prima che riparta (e guadagnare punti bonus col Sig. Giorgio). Grazie alla mia Bea, perché anche se ci sentiamo o vediamo a distanza di mesi è sempre come se fosse passato un giorno. E grazie pure a Diego, finalmente qualcuno che mi ascolta davvero quando ho aneddoti da raccontare! E poi ha sempre qualcosa di interessante da chiedere o dire. Grazie a Happy, per un milione di ragioni che non riesco a ridurre a qualche riga. E poi hai già la dedica, non basta?

Grazie a Paolo, per le risate, la sua presenza e il suo affetto. E poi, è il migliore creatore di *hashtag* che ci sia. #thankspaoloeverywhere

Grazie alla Maura (Salvatori!). Galeotta fu l'analisi 3, e ora ho una prof, un'amica, un sostegno. E pure il contatto Skype.

Grazie al Pit, Massetti-Monguzzi Vs Moser: 1-0.

E grazie a Spillo, perché è come un fratello.

Merci à ma "famille" française, Pascal et Martine, car ils me traitent comme leur fille. Chez eux je me sens comme chez moi + un potager et je ne rentre jamais sur Paris les mains vides. Merci à Romain, puisque il me remercie toujours dans ses remerciement car je lui dis de me remercier, donc là j'ai un coup d'avance et je peux gagner une place dans ceux de sa thèse, sans ne devoir rien demander.

Merci à Claire-Line, pour toutes les soirées ensembles, les expos, les cinés, les restos, les blagues et son amitié. Quoiqu'il m'arrive, elle trouve toujours du temps pour me voir.

Merci à Jean, le meilleur croque-lardon au monde. T'avoir chez moi rime toujours avec blagues inopportunes, culture poussée, musique indépendante, humour, expressions françaises au goût retrò, famille. Et puis, tu es à Cambridge mais aujourd'hui tu es là...solide !

Merci à Elise, pour son esprit libre, ouvert et cultivé. Les heures à parler des "grandes questions" volent toujours, et à chaque fois je rêve de la prochaine soirée-taboulé.

Le "merci Andy" (et tout ce qui entraîne) prendra effet à la sortie mondiale du film "5 sur 4 de français à NY". Stay tuned !

Merci à Chloé et son "esprit râleur". C'est rare de trouver quelqu'un aussi tranchant que adorable, et ton admiration manifeste à l'Italie fait toujours du bien:)

Merci à Alicia, pour son intérêt sincère à mon travail et à mes projets futurs, à l'Italie et à mes histoires.

Merci à mes chers Duellistes, Maitre Sando, Nilu, Eric, Raphaëlle, Charlotte, Nath, Apo, Olivier, Eglantine, Aurélie, Julien, Vinciane et Tara car on ne sait pas pourquoi mais ils sont toujours intéressés à mes histoires de maths, de TDs, de post-doc, de littérature, d'Italie...vous étiez (et continuez à l'être) le pic de mes semaines et votre support c'est tellement génuine.

Merci à Maryame, puisque même à six milles kilomètres de distance elle est présente comme avant, avec sa force et son sourire perçants, prête à me secouer quand il faut, sans jamais arrêter de croire en moi. "Les skypes" avec toi chauffent toujours le cœur.

Et merci à Alex, mon épaule, mon sourire, mon ami, mon cœur.

Nomenclature

$\mathcal{A}(U_s, V_s)$ the set of analytic functions defined from one complex extension to another

\mathcal{G} set of germs of real analytic isomorphisms of $\mathbb{T}^n \times \mathbb{R}^n$ of the form

$$g(\theta, r) = (\varphi(\theta), R_0(\theta) + R_1(\theta) \cdot r)$$

\mathcal{G}^ω set of germs of symplectomorphism

$$g(\theta, r) = (\varphi(\theta), {}^t\varphi'^{-1}(\theta) \cdot (r + dS(\theta) + \xi))$$

\mathcal{G}^{Ham} set of germs of exact symplectomorphism of the form

$$g(\theta, r) = (\varphi(\theta), {}^t\varphi'^{-1}(\theta) \cdot (r + dS(\theta)))$$

\mathcal{H} set of germs of real analytic Hamiltonians along \mathbb{T}_0^n

\mathcal{K}^α affine subspace of \mathcal{H} of Hamiltonians of the form

$$K(\theta, r) = c + \alpha \cdot r + O(r^2)$$

\mathbb{T}_0^n the torus $\mathbb{T}^n \times \{0\} \subset \mathbb{T}^n \times \mathbb{R}^n$

\mathbb{T}_s^n the complex extension of width s of the manifold $\mathbb{T}^n \times \mathbb{R}^n$

$\mathbb{T}_{\mathbb{C}}^n$ the complex manifold $\mathbb{T}_{\mathbb{C}}^n \times \mathbb{C}^n$

$\mathbb{T}_{\mathbb{C}}^n$ the complex torus $\mathbb{C}^n / 2\pi\mathbb{Z}^n$

\mathbb{T}_s^n the complex extension of width s of the torus \mathbb{T}^n

$\mathcal{U}(\alpha, A)$ affine subspace of \mathcal{V} of vector fields of the form

$$u(\theta, r) = (\alpha + O(r), A \cdot r + O(r^2))$$

$\mathcal{U}^{\text{Ham}}(\alpha, -\eta)$ space of Hamiltonian vector fields $\mathcal{U}^{\text{Ham}}(\alpha, 0)$ extended with the non Hamiltonian term $-\eta r$

$\mathcal{U}^{\text{Ham}}(\alpha, 0)$ affine subspace of \mathcal{V}^{Ham} of vector fields of the form

$$u^{\text{H}}(\theta, r) = (\alpha + O(r), O(r^2))$$

\mathcal{V} set of germs of real analytic vector fields along \mathbb{T}_0^n

\mathcal{V}^{Ham} set of germs of real analytic Hamiltonian vector fields along \mathbb{T}_0^n

$\mathcal{V}^{\text{Ham}} \oplus (-\eta r \partial_r)$ space of vector fields \mathcal{V}^{Ham} extended with the non Hamiltonian term $-\eta r$

$v^{\text{H}} \oplus (-\eta r \partial_r)$ vector fields belonging to $\mathcal{V}^{\text{Ham}} \oplus (-\eta r \partial_r)$

$X(\theta, r) \partial_\theta$ contracted notation for $\sum_j^n X^j(\theta, r) \frac{\partial}{\partial \theta_j}$

$X(\theta, r) \partial_r$ contracted notation for $\sum_j^n X^j(\theta, r) \frac{\partial}{\partial r_j}$

Introduction

The so-called "KAM theory", initiated by Kolmogorov in 1954, has at its heart the study of quasi-periodic motions (that is to say a superposition of finitely many oscillatory motions of different frequencies) and, more specifically, their persistence under small perturbation. This theory plays a fundamental role in the study of conservative dynamical systems, as one encounters notably in Celestial Mechanics.

In particular, Arnold in the 1960's, proved an important theorem that can be roughly summarized in this way: if planets' masses had been sufficiently small with respect to that of the Sun (in fact incomparably smaller than real masses themselves), for a *large* (in the sense of measure) subset of initial conditions (initial positions and velocities of planets), the movement of planets would have been bounded and without collisions, like their Keplerian approximation. This is an outstanding result of stability, even if, on the one hand it does not apply to the Solar System itself, and on the other one, even under the hypothesis that masses are sufficiently small, it does not apply neither to *every* nor to generic initial condition.

This theory has been developed for general conservative systems, in particular for Hamiltonian ones.

One of the first generalizations to non necessarily conservative systems is due to Moser, who, in 1967, established a remarkable normal form for analytic perturbations of vector fields possessing a reducible invariant torus carrying a reducible quasi-periodic Diophantine flow. His interest was on perturbations of systems of the form

$$(0.1) \quad \begin{cases} \dot{\theta} = \alpha + O(r), & \alpha \in \mathbb{R}^n \\ \dot{r} = A \cdot r + O(r^2), & A \in \text{Mat}_m(\mathbb{R}), \end{cases}$$

in a neighborhood of $T_0^n := \mathbb{T}^n \times \{r = 0\}$ in $\mathbb{T}^n \times \mathbb{R}^m$. For systems like this, T_0^n is invariant, quasi-periodic and reducible.

Unperturbed equations describing real physical problems, taking into account some dissipation forces, can naturally be written in this form.

In the case of planets, these dissipative effects are due to internal frictions caused by their deformations under the gravitational field (tides), and have

a long term influence on their movements and the one of their satellites. Today the influence of dissipation on the rotation of satellites is a main object of interest.

The astronomical problem that motivated this work is the so called "dissipative spin-orbit problem", previously presented in the works of Celletti-Chierchia [CC09] and Stefanelli-Locatelli [SL12].

Starting from the normal form of Moser we build a more geometrical context in which it becomes natural to deduce other normal form results, depending on the system under study; as an application, we prove a KAM-type result for the aforementioned spin-orbit problem.

This approach naturally leads to a better understanding of the dynamical role of the parameters at stake in the normal form and opens on a further study of the geometry of the space of parameters involved.

From the normal form of Moser... The first chapter of this thesis is dedicated to the theorem of Moser which although it has been used by various authors, has remained relatively unnoticed for several years.

We present an alternative proof of this result which consists in finding the solution of a non linear functional equation through an abstract inverse function theorem in analytic class (theorem 1.4). Although the difficulties to overcome in this proof are the same as in the original one (proving the fast convergence of a Newton-like scheme), it relies on a relatively general inverse function theorem (unlike in Moser's approach), following an alternative strategy with respect to the one proposed by Zehnder in [Zeh75].

Let us state the normal form result.

Let \mathcal{V} be the space of germs of real analytic vector fields along $\mathbb{T}^n \times \{0\}$ in $\mathbb{T}^n \times \mathbb{R}^m$ and $\mathcal{U}(\alpha, A)$ be its affine subspace consisting of vector fields like (0.1) where $\alpha \in \mathbb{R}^n$ and $A \in \text{Mat}_m(\mathbb{R})$ are *fixed*. A is supposed to be diagonalizable with eigenvalues $a = (a_1, \dots, a_m)$ and we assume that among the linear combinations

$$ik \cdot \alpha + l \cdot a \quad (k, l) \in \mathbb{Z}^n \times \mathbb{Z}^m, |l| \leq 2, \quad |l| = |l_1| + \dots + |l_m|$$

there are only finitely many which vanish. Moreover we impose the following Diophantine condition on $\alpha \in \mathbb{R}^n$ and the eigenvalues $(\bar{a}, 0) = (a_1, \dots, a_\mu, 0, \dots, 0) \in (\mathbb{C}^*)^\mu \times \mathbb{C}^{m-\mu}$, for some real positive γ, τ ,

$$|ik \cdot \alpha + l \cdot \bar{a}| \geq \frac{\gamma}{(1 + |k|)^\tau} \quad \text{for all } (k, l) \in \mathbb{Z}^n \times \mathbb{Z}^m \setminus \{(0, 0)\}.$$

Let Λ be the subspace of \mathcal{V} of constant vector fields of the form

$$\lambda(\theta, r) = (\beta, b + B \cdot r), \quad b \in \mathbb{R}^m, B \in \text{Mat}_m(\mathbb{R}) : A \cdot b = 0, [A, B] = 0$$

In the following we will refer to λ as (*external*) *parameters* or *counter terms*. Eventually let \mathcal{G} be the space of germs of real analytic isomorphisms of

$\mathbb{T}^n \times \mathbb{R}^m$ of the form

$$g(\theta, r) = (\varphi(\theta), R_0(\theta) + R_1(\theta) \cdot r),$$

φ being a diffeomorphism of the torus fixing the origin and R_0, R_1 being respectively an \mathbb{R}^m -valued and $\text{Mat}_m(\mathbb{R})$ -valued functions defined on \mathbb{T}^n .

THEOREM (Moser 1967). *If $v \in \mathcal{V}$ is close enough to $u^0 \in \mathcal{U}(\alpha, A)$ there exists a unique triplet $(g, u, \lambda) \in \mathcal{G} \times \mathcal{U}(\alpha, A) \times \Lambda$ such that $v = g_* u + \lambda$.*

The notation $g_* u$ indicates the push-forward of u by g .

The introduction of the parameter $\lambda \in \Lambda$ is a powerful trick that switches the frequency obstruction (obstruction to the conjugacy to the initial dynamics) from one side of the conjugacy to the other. Although the presence of the counter-term λ breaks the dynamical conjugacy down, it is a *finite dimensional* obstruction: geometrically, the \mathcal{G} -orbits of all u 's in $\mathcal{U}(\alpha, A)$ form in \mathcal{V} a submanifold of finite co-dimension $N \leq n + m + m^2$, transversal to Λ .

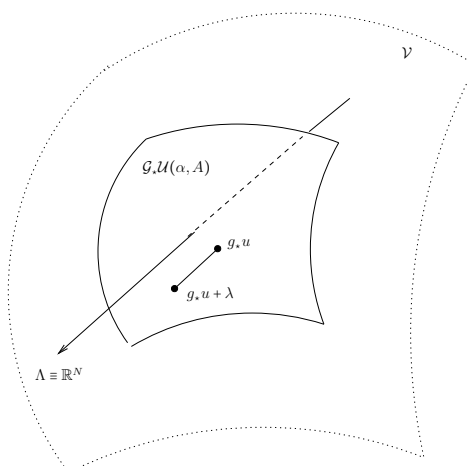

Notice that, in general, v cannot be of the form $v = g_*(u + \lambda)$; as a matter of fact the operator $(g, u, \lambda) \mapsto g_*(u + \lambda)$ is not open despite it has the same invertible derivative¹ as $(g, u, \lambda) \mapsto g_*u + \lambda$ at $(\text{id}, u^0, 0)$: having an invariant torus is not an open property (see [Sev03]). In fact, it is not hard to see that the linearized equation, at a point close to $(\text{id}, u^0, 0)$, associated to $(g, u, \lambda) \mapsto g_*(u + \lambda) = v$ is

$$[g_*(u + \lambda), \delta g \circ g^{-1}] + g_*(\delta u + \delta \lambda) = \delta v$$

which is not invertible at (g, u, λ) if $(\alpha + \beta, A + B)$ is Liouville or resonant.

¹At this level all this may sound vague as we haven't specified target and source spaces yet, but this should not deprive the heuristic idea of its importance.

The functional setting in which we prove the theorem of Moser is an alternative to the one proposed by Zehnder in his remarkable papers [Zeh75]-[Zeh76]. Although both approaches rely on the fact that the convergence of the Newton scheme is somewhat independent of the internal structure of variables, they differ for the following reason: inverting the operator

$$\phi : (g, u, \lambda) \mapsto g_* u + \lambda = v,$$

as we will in chapter 1, is equivalent to solving implicitly the pulled-back equation ($g^* = g_*^{-1}$)

$$\Phi(g, u, \lambda; v) = g^*(v - \lambda) - u = 0,$$

with respect to u, g and λ as Zehnder did. The problem is that whereas ϕ is a local diffeomorphism (in the sense of scales of Banach spaces), the linearization of Φ ,

$$\frac{\partial \Phi}{\partial (g, u, \lambda)}(g, u, \lambda; v) \cdot (\delta g, \delta u, \delta \lambda) = [g^*(\lambda - v), g'^{-1} \cdot \delta g] + g^* \delta \lambda + \delta u$$

is not surjective if for instance $g^*(\lambda - v)$ is Liouville. It is invertible in a whole neighborhood of $\Phi = 0$ only up to a second order term (see Zehnder [Zeh75, §5]), which prevents us from using a Newton scheme in a straightforward manner.

...to other normal forms. What motivated this work is the paper [CC09] by Celletti and Chierchia about the persistence of quasi-periodic attractors in Celestial Mechanics in the case of the so called "dissipative spin-orbit problem". This problem and other astronomical ones can be reformulated in terms of normal forms.

The first attempt when studying real astronomical problems subject to dissipative effects is to consider systems in which the dissipation term troubles the equations of motion with a linear friction term (whose precise characteristics is very difficult to determine), while the remaining interactions are still Hamiltonian.

In this line of thought, in the second chapter, section (2.1), we start by presenting Moser's theorem in the purely **Hamiltonian context** (proved independently by Herman and present in Féjóz's works [Féj04] and [Féj10] as the "twisted conjugacy" theorem).

Vector fields $v^H \in \mathcal{V}^{\text{Ham}} \subset \mathcal{V}$ involved correspond to real analytic Hamiltonians H defined in a neighborhood of \mathbb{T}_0^n , the corresponding $u^H \in \mathcal{U}^{\text{Ham}}(\alpha, 0)$ possessing an invariant torus come from $K(\theta, r) = \alpha \cdot r + O(r^2)$ instead:

$$u^H = \begin{cases} \dot{\theta} = \alpha + O(r) \\ \dot{r} = O(r^2). \end{cases}$$

In this case the dimension of the obstruction λ is reduced to n and the diffeomorphisms at stake are Hamiltonian. From this context, slightly modifying the class of these vector fields by adding the aforementioned dissipative linear term² in the normal direction $u^H \oplus (-\eta r \partial_r)$, $\eta \in \mathbb{R}^+$ (see section "**Hamiltonian + dissipation**"), it is possible to prove a first generalization to dissipative systems (see section 2.2 and theorem 2.3 baptized "Herman dissipative") in which the number of needed external parameters breaking the dynamical conjugacy is the same as in the purely Hamiltonian context (a translation term $\beta \partial_\theta$, $\beta \in \mathbb{R}^n$ in the angle's direction). For this to be true it is fundamental that dissipation acts the same in any direction: the constant matrix A appearing in r -directions is a homothety $-\eta \text{id}$.

In a second step, we add a **twist hypothesis** on the Hamiltonian vector fields assuming that the average of the coefficient of the quadratic term in $K(\theta, r) = \alpha \cdot r + \frac{1}{2}Q(\theta) \cdot r^2 + O(r^3)$ is a non degenerate quadratic form: $\det \int_{\mathbb{T}^n} Q \neq 0$. In this context it is natural to take advantage of this non degeneracy condition and perform transformations by symplectic diffeomorphisms. Because of the presence of the constant term $-\eta r \partial_r$ we obtain a translated torus result via a normal form theorem (see section 2.4 and the theorem "à la Rüssmann" therein) that can be considered as an analog for vector fields in this class of the celebrated Rüssmann translated curve theorem for diffeomorphisms of the annulus (see [Rüs70]). As a matter of fact we prove that the operator

$$(0.2) \quad \phi : (g, u, b) \mapsto g_* u + b \partial_r = v, \quad b \in \mathbb{R}^n$$

is a local diffeomorphism, the image of the torus $g(\mathbb{T}_0^n)$ by the flow of v is translated by b .

The more **general dissipative** case in which no Hamiltonian hypothesis is made and the dissipative term is provided by a more general diagonal matrix $A \cdot r$ with negative real entries, is also given as a straightforward corollary to Moser's theorem.

We eventually summarize these results in two diagrams that give a portrait of these dissipative systems in terms of normal forms.

Invariant tori: elimination of parameters. It is now evident that in several situations the number of counter terms a priori needed to solve the conjugacy equation $g_* u + \lambda = v$ can be considerably reduced when symmetries are present in the system. The fact that the submanifold $\mathcal{G}_* \mathcal{U}(\alpha, A)$ has finite co-dimension leaves the possibility that in some cases these obstructions can be even totally eliminated if the system depends in an opportune way

²We noted $\partial_r = (\partial_{r_1}, \dots, \partial_{r_n})$ and omitted the tensor product sign $r \otimes \partial_r$.

on a sufficient number of free parameters - either internal or external parameters. When $\lambda = 0$, the image $g(T_0^n)$ is invariant for v and u determines the first order dynamics along this torus. The *infinite* dimensional conjugacy problem is reduced to a *finite* dimensional one.

In some cases the crucial point is to allow frequencies $(\alpha_1, \dots, \alpha_n, a_1, \dots, a_m)$ to vary, using the fact that λ is Whitney-smooth with respect to them (see appendix B). Herman understood the power of this reduction in the 80's (see [Sev99]) and other authors (Rüssmann, Sevryuk, Chenciner, Broer-Huitema-Takens, Féjóz...) adopted this technique of "elimination of parameters" to prove invariant tori theorems in multiple contexts, at various level of generality, contributing to clarify this procedure. For the sake of completeness, in appendix B we included a "hypothetical translated torus" theorem in the frame of the previous observations, proved by adapting to this normal forms the "hypothetical conjugacy" theorem by Féjóz in [Féj04] or [Féj10].

In chapter 3, we will show that the central result of Celletti-Chierchia in [CC09, Theorem 1] and Stefanelli-Locatelli in [SL12, Theorem 3.1] (who generalize the work of Celletti-Chierchia to any dimension) can be deduced from the translated torus theorem of section 2.4 and the elimination of the translation parameter " b " (see sections 3.1.1 and 3.2.2).

The spin-orbit problem. Celletti and Chierchia in [CC09] study the dissipative spin-orbit model given by the following equation of motion in \mathbb{R} :

$$(0.3) \quad \ddot{\theta} + \eta(\dot{\theta} - \nu) + \varepsilon \partial_{\theta} f(\theta, t) = 0,$$

where (θ, t) are 2π -periodic variables.

This equation describes the dynamics of the rotation about its spin axis (represented by the angular variable θ) of a triaxial body whose center of mass revolves along a given elliptic Keplerian orbit around a fixed massive point. The rotation axis is perpendicular to the orbital plane. The internal structure of the body is non-rigid and contributes with some linear friction (represented by $\eta\dot{\theta}$, $\eta \in \mathbb{R}^+$) under gravitational forces. In the case of a triaxial ellipsoid with different equatorial axis, the calculation of the potential gives out a supplementary term $\varepsilon \partial_{\theta} f(\theta, t)$ where $\varepsilon = \frac{B-A}{C}$ is proportional to the difference of the two smallest axes of inertia. The external parameter $\nu \in \mathbb{R}$ is the proper frequency of the attractor of the dynamics when $\varepsilon = 0$.

In their approach Celletti-Chierchia look for a function $u : \mathbb{T}^2 \rightarrow \mathbb{R}$ such that the solution of (0.3) can be written as

$$\theta(t) = \alpha t + u(\alpha t, t),$$

α being a fixed Diophantine frequency.

Provided that ε is small enough, for any $\eta \in [-\eta_0, \eta_0]$ the function u is

eventually found as the solution of an opportune PDE, for a particular value of ν (see [CC09, Theorem 1] for the precise statement).

The feeling that the above result could be found as a consequence of the theorem of Moser or a similar normal form theorem adapted to this precise context represented the main motivation of this work.

In our framework the problem becomes:

The vector field corresponding to equation (0.3) after the convenient introduction of α by translating the "action" variable r , reads

$$\begin{cases} \dot{\theta} = \alpha + r \\ \dot{r} = -\eta r + \eta(\nu - \alpha), \end{cases}$$

when $\varepsilon = 0$. For every Diophantine α the torus $r = 0$ is invariant, provided $\nu = \alpha$.

Can we prove the persistence, under perturbation, of this invariant attractor for a particular value of ν , close to α ?

The existence of the attractive torus is shown in two steps. By the translated torus theorem 2.5 adapted to this particular context (corollary 3.2.1), one proves that, provided the perturbation is small enough, a normal form like (0.2) exists for any values of $\eta \in [-\eta_0, \eta_0]$. In a second step one shows that the translation b can be eliminated by implicitly solving $b(\alpha, \nu, \eta, \varepsilon) = 0$ for a unique choice of ν , on which b smoothly depends. Since the maximal bound of the perturbation ε turns out to be uniform with respect to η , the smooth dependence on parameters allows to define, for every Diophantine α , a surface $\nu = \nu(\eta, \varepsilon)$ in the space (η, ν, ε) on which the counter terms $b(\alpha, \nu, \eta, \varepsilon)$ vanish, guaranteeing the existence of reducible α -quasi-periodic attractive (resp. repulsive, when $\eta < 0$) invariant tori (see theorem 3.2 and corollary 3.2.2). Every plan $\varepsilon = \text{const.}$ (ε being an admissible perturbation), thus carries a Cantor set of curves C_α , along which the counter term $b(\alpha, \nu, \eta, \varepsilon) = 0$. See figures in the next page.

The parameter space of the spin-orbit problem. This is the starting point of a further study that aims at understanding which kind of dynamics takes place for values of parameters in between these curves C_α .

In chapter 4 we aim at delimiting regions of the parameter' space (dissipation, frequency, perturbation) of the spin-orbit problem where the dynamics, or at least some of its important features, are understood. For technical reasons this is done by studying the corresponding family of time- 2π maps.

This analysis is motivated by three works of Chenciner in the 80's [Che85a]-[Che85b]-[Che88] in which he studied the dynamical properties of generic

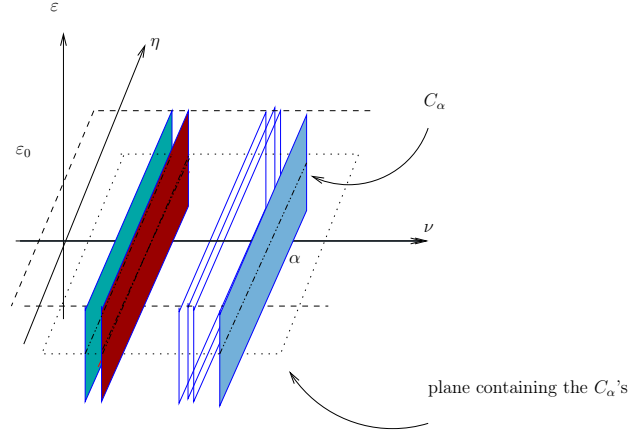

FIGURE 1. The Cantor set of surfaces: transversely cutting with a plane $\varepsilon = \text{const}$ we obtain the Cantor set of curves like the one described in theorem 3.2

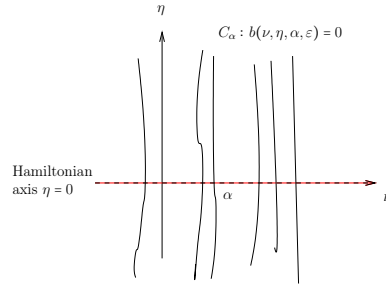

FIGURE 2. The Cantor set of curves whose points correspond to an attractive/repulsive invariant torus

2-parameter families of germs of diffeomorphisms of \mathbb{R}^2 which unfold an elliptic fixed point. In the same spirit as the first of these three works, we are at first interested in delimiting regions in which the normal hyperbolicity is sufficiently strong to guarantee the persistence of an invariant attractive (or repelling) circle under perturbation.

To give a more precise idea, our study starts from the general solution of (0.3) for $\varepsilon = 0$,

$$\begin{cases} \theta(t) = \theta(0) + \nu t + [r(0) - (\nu - \alpha)] \frac{1 - e^{-\eta t}}{\eta} \\ r(t) = r(0) + (e^{-\eta t} - 1)[r(0) - (\nu - \alpha)]. \end{cases}$$

The period of the perturbation being 2π , we are interested in the map

$$P(\theta(0), r(0)) = (\theta(2\pi), r(2\pi)).$$

The circle $r = r(0)$ is translated by the quantity

$$\tau = r(2\pi) - r(0) = (e^{-2\pi\eta} - 1)(r(0) - (\nu - \alpha))$$

and rotated by the angle

$$\begin{aligned}\theta(2\pi) - \theta(0) &= 2\pi\nu + [r(0) - (\nu - \alpha)] \frac{1 - e^{-2\pi\eta}}{\eta} \\ &= 2\pi\nu - \frac{\tau}{\eta}.\end{aligned}$$

In particular, the unique circle which is rotated by an angle $2\pi\alpha$ is the one with radius

$$r_\alpha = (\nu - \alpha) \left[1 + \frac{2\pi\eta}{e^{-2\pi\eta} - 1} \right];$$

this circle is translated by the quantity

$$\tau_\alpha = 2\pi\eta(\nu - \alpha).$$

At first, we center coordinates at the invariant circle of rotation number $2\pi\nu$ of P and prove, via the method of the "graph transform", that for high enough values of the dissipation η , this circle persists under small perturbations, no matter what $2\pi\nu$ is. As a result, there exists a first region where the normal hyperbolicity prevails over all the rest (see theorem 4.1).

We then focus on the translated circle of rotation $2\pi\alpha$ introducing the translation function τ_α and, adapting Rüssmann's theorem to this context, we perform a second localization (section 4.2), and use all the strength of the Diophantine properties of α to derive a normal form of the perturbed diffeomorphism. It is then possible to identify a larger region in which, again, the normal hyperbolicity is strong enough to imply the existence of a normally hyperbolic invariant circle (section 4.2, theorem 4.2).

In appendix A, we prove a 2-dimensional discrete time analogue of Moser's theorem. We deduce Rüssmann's translated curve theorem in analytic class, once a twist property is assumed.³ Moreover, Rüssmann's translated curve theorem in the spin-orbit 2π -flow with general perturbations, entails the existence of curves along which the translation vanishes, thus guaranteeing the existence of invariant quasi-periodic circles for generic analytic perturbations Q of P , for sufficiently strong values of η with respect to the perturbation.

These last results complete the first portrait of the geometry of the space of parameters of the spin-orbit problem and stress even more the existence of an **important dichotomy** between the class of dissipative systems with Hamiltonian perturbations and the ones with generic perturbations.

The existence of curves C_α in the plane (η, ν) for *any* values of η provided

³Up to our knowledge in the literature this theorem is always presented in smooth or finite differentiability category but not in the analytic one.

in the context of vector fields, is possible because of the Hamiltonian perturbations. For non Hamiltonian perturbations, these curves are not supposed to reach the $\eta = 0$ axis (see section 3.3).

This is even more evident in the context of diffeomorphisms, for the generic perturbation of the spin-orbit time 2π -map that we considered (not disposing of the explicit corresponding solution). The general belief is that for no reason an invariant curve should resist *any* kind of perturbations for *any* values of dissipation/normal hyperbolicity η . In the complement of regions where normal hyperbolicity is strong, the dynamics is expected to be very rich, as is the portrait given by Chenciner.

CHAPTER 1

The normal form of Moser

This the starting point to other results in this spirit of "introducing external parameters" of Moser and Herman (see next chapter) intended to give a more complete portrait of dissipative systems in terms of normal forms.

1.1. Overview

The original statement of Moser concerned systems defined on the general phase space $\mathbb{T}^n \times \mathbb{R}^m$ with n and m non necessarily equal. The way we present the problem on $\mathbb{T}^n \times \mathbb{R}^n$ instead, does not have an impact on the difficulty of solving it; it rather seemed to be more naturally connectable with the even more particular case that will be the center of the first part of this thesis, dissipative systems coming from real physical problems.

We are interested in analytic vector fields defined by the following system of differential equations in the neighborhood of $\mathbb{T}_0^n := \mathbb{T}^n \times \{r = 0\} \subset \mathbb{T}^n \times \mathbb{R}^n$

$$(1.1) \quad u : \begin{cases} \dot{\theta} = \alpha + O(r) \\ \dot{r} = A \cdot r + O(r^2), \end{cases}$$

where $\theta = (\theta_1, \dots, \theta_n)$ are n angular variables of period 2π , and $r = (r_1, \dots, r_n)$ are real variables. In particular α is a constant vector belonging to \mathbb{R}^n , and A a diagonalizable matrix in $\text{Mat}_n(\mathbb{R})$, with eigenvalues $a = (a_1, \dots, a_n)$. The notation $O(r^k)$ stands for higher order terms in r , that may depend on θ as well. The special feature with vector fields of this kind is that they possess a reducible invariant quasi-periodic torus, \mathbb{T}_0^n .

We will refer to $\alpha_1, \dots, \alpha_n, a_1, \dots, a_n$ as the *characteristic exponents* or *characteristic numbers* of \mathbb{T}_0^n .

REMARK 1.1. *That vector fields have a linear component in the r -direction which is a constant matrix, constitutes a strong hypothesis. If we think of a Taylor's expansion along \mathbb{T}_0^n of a general vector field, we would have something of the form $\dot{r} = \underline{\text{const}} + A(\theta) \cdot r + O(r^2)$, because nothing ensures that the linearized part has to be constant; in general there is no change of variables that makes A independent of the angles (see [Cha10], for instance).*

The question here is whether this kind of dynamics in a neighborhood of T_0^n , persists under perturbation.

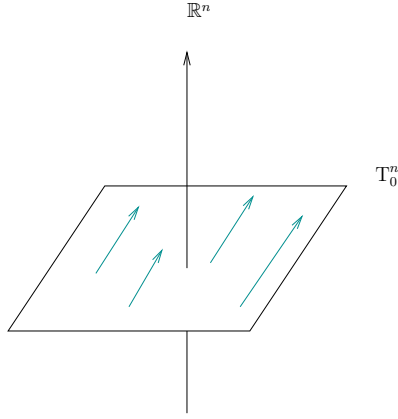

FIGURE 1. Linear flow on the invariant torus

Let us perturb (1.1),

$$(1.2) \quad v: \begin{cases} \dot{\theta} = \alpha + O(r) + \varepsilon f(\theta, r) \\ \dot{r} = A \cdot r + O(r^2) + \varepsilon g(\theta, r), \end{cases}$$

where $\varepsilon \ll 1$ and f, g are real analytic functions in all their variables.

Is there a change of variables transforming v back to a form like (1.1), with **the same** characteristic numbers $\alpha_1, \dots, \alpha_n, a_1, \dots, a_n$?

This question calls for two important comments: on the one hand we stress the fact that the perturbation is very general, not of Hamiltonian nature nor of any particular form; on the other there is no reason that tangent and normal frequencies stay the same after a perturbation. Behind the last fact, the following classical result holds

PROPOSITION 1.1.1. *The frequency vector $\alpha \in \mathbb{R}^n$ is a topological conjugacy invariant, up to the action of the general linear group $\text{GL}_n(\mathbb{Z})$: if two linear flows $\alpha t + \theta$ and $\beta t + \theta$ are topologically conjugated, there exists $A \in \text{GL}_n(\mathbb{Z})$ such that $\beta = A\alpha$.*

In addition, consider A as a fixed diagonal matrix of pairwise distinct eigenvalues a_1, \dots, a_n and an arbitrary matrix close to A , say $A + D$. In general it is not possible to find a transformation T such that $A + D$ is similar to A by T , as eigenvalues must agree with those of A . Instead, by the implicit function theorem there exists a diagonal matrix B , such that the *modified* matrix $A + D + B$ is similar to A : $A + D + B = TAT^{-1}$.

For these reasons we are forced to introduce some "external parameters" to compensate the degeneracy caused by the invariance of frequencies: we modify v by the so-called *modifying terms* or *counter terms*

$$(1.3) \quad \tilde{v} := \begin{cases} \dot{\theta} = \alpha + O(r) + \varepsilon f(\theta, r) - \beta \\ \dot{r} = A \cdot r + O(r^2) + \varepsilon g(\theta, r) - b - B \cdot r, \end{cases}$$

β and b being constant vectors belonging to \mathbb{R}^n and B a matrix in $\text{Mat}_n(\mathbb{R})$ satisfying $A \cdot b = 0, [A, B] = 0$ respectively. These conditions will guarantee that the existence of such parameters is unique.

Of course, if we want some persistence result to hold, we have to ask our frequencies to satisfy some arithmetic properties in order to avoid *resonances*, in the sense that

$$\exists k \in \mathbb{Z}^n \setminus \{0\}, \text{ such that } k \cdot \alpha = k_1 \alpha_1 + \dots + k_n \alpha_n = 0.$$

To get a heuristic idea of resonances, think about two planets revolving about the Sun with frequencies α_1 and α_2 respectively, that periodically find themselves in the same mutual position: the gravitational attraction between them will not cancel out in time average, but instead will pile up.

Let $\gamma, \tau > 0$ be positive real numbers.

The vector $\alpha \in \mathbb{R}^n$ is called (γ, τ) -Diophantine if it satisfies the following Diophantine condition:

$$(1.4) \quad |k \cdot \alpha| \geq \frac{\gamma}{|k|^\tau}, \quad \forall k \in \mathbb{Z}^n \setminus \{0\}, \quad |k| := |k_1| + \dots + |k_n|.$$

Actually we will require the characteristic numbers $\alpha \in \mathbb{R}^n$ and $(\bar{a}, 0) = (a_1, \dots, a_\mu, 0, \dots, 0) \in (\mathbb{C}^*)^\mu \times \mathbb{C}^{n-\mu}$ to satisfy the following inequality

$$(1.5) \quad |ik \cdot \alpha + l \cdot \bar{a}| \geq \frac{\gamma}{(1 + |k|)^\tau} \quad \text{for all } (k, l) \in \mathbb{Z}^n \times \mathbb{Z}^\mu \setminus \{(0, 0)\}, \quad |l| \leq 2.$$

If τ is large enough and γ is small enough, the measure of the set of "good frequencies" tends to the full measure as γ tends to zero. For proofs about these facts and further details we refer to [Pös89] and [Pös01] and references therein.

The module's arguments at the left hand sides of inequalities (1.4) and (1.5) are the so called "small divisors" that will pop up when trying to solve the linearized conjugacy problem, indeed the problem itself.

We are now ready to state the main result:

THEOREM 1.1 (Moser, 1967). *Let us consider a system like (1.2). Suppose that A is diagonalizable and that its eigenvalues a_1, \dots, a_n together with $\alpha_1, \dots, \alpha_n$ satisfy the diophantine condition (1.5). If the functions f and g are analytic and ε is small enough, there exist an analytic change of variables defined in a neighborhood of $\mathbb{T}^n \times \{0\}$, and three counter terms $\beta(\varepsilon), b(\varepsilon)$*

and $B(\varepsilon)$, uniquely defined and depending analytically on ε , such that the modified system (1.3) can be transformed into

$$(1.6) \quad \tilde{u} : \begin{cases} \dot{\tilde{\theta}} = \alpha + O(\tilde{r}) \\ \dot{\tilde{r}} = A \cdot \tilde{r} + O(\tilde{r}^2), \end{cases}$$

meaning that it possesses a quasi-periodic solution with the same characteristic exponents as u .

1.2. Functional setting

Let \mathcal{V} be the space of germs of real analytic vector fields along $\mathbb{T}_0^n := \mathbb{T}^n \times \{0\} \subset \mathbb{T}^n \times \mathbb{R}^n$.

Fix $\alpha \in \mathbb{R}^n$ and $A \in \text{Mat}_n(\mathbb{R})$ diagonalizable of eigenvalues a_1, \dots, a_n and let $\mathcal{U}(\alpha, A)$ be the affine subspace of \mathcal{V} consisting of vector fields of the form

$$(1.7) \quad u(\theta, r) = (\alpha + O(r), A \cdot r + O(r^2)),$$

where $O(r^k)$ stands for terms of order $\geq k$ in r , that may depend on θ as well. This subspace consists of vector fields for which the torus \mathbb{T}_0^n is invariant and carries a reducible α -quasi-periodic dynamics with Floquet exponents a_1, \dots, a_n .

Let \mathcal{G} be the space of germs along \mathbb{T}_0^n of real analytic isomorphisms of the form

$$g(\theta, r) = (\varphi(\theta), R_0(\theta) + R_1(\theta) \cdot r),$$

φ being a diffeomorphism of the torus \mathbb{T}^n fixing the origin, and R_0 and R_1 some \mathbb{R}^n and $\text{Mat}_n(\mathbb{R})$ -valued functions respectively, defined on the torus \mathbb{T}^n as well.

Let finally Λ be the finite-dimensional space of vector fields in $\mathbb{T}^n \times \mathbb{R}^n$ of the form

$$\lambda(\theta, r) = (\beta, b + B \cdot r),$$

$\beta, b \in \mathbb{R}^n$ and $B \in \text{Mat}_n(\mathbb{R})$, satisfying $A \cdot b = 0$, $[A, B] = 0$.

We will also use the notation

$$X(\theta, r) = \sum_{i=1}^n f^i(\theta, r) \frac{\partial}{\partial \theta_i} + g^i(\theta, r) \frac{\partial}{\partial r_i}, \quad \text{or } X(\theta, r) = f(\theta, r) \partial_\theta + g(\theta, r) \partial_r,$$

for

$$X(\theta, r) = (f(\theta, r), g(\theta, r)).$$

But no ambiguity will occur: all vector fields here always have $2n$ components, n in the direction of θ and n in the direction of r , to which we refer as the *tangent* and *normal* directions.

With these new objects, we can state the theorem of Moser in a more compact form:

THEOREM 1.2 (Moser, 1967). *If v is close enough to some $u^0 \in \mathcal{U}(\alpha, A)$, there exists a unique triplet $(g, u, \lambda) \in \mathcal{G} \times \mathcal{U}(\alpha, A) \times \Lambda$ such that the equation*

$$(1.8) \quad g_* u = v - \lambda$$

is satisfied.

The notation $g_* u$ indicates the push-forward via of u via g . When $\lambda = 0$, $g(\mathbb{T}_0^n)$ is the invariant torus of v , and u its first order normal form along the manifold.

The stringent requirement we made about the characteristic numbers to be fixed, causes an obstruction (of finite dimension) to the dynamical conjugacy between v and u , represented by the presence of λ on the "other side" of the conjugation. Geometrically, this means that in \mathcal{V} the \mathcal{G} -orbits of u 's $\in \mathcal{U}(\alpha, A)$, $\mathcal{G}_* \mathcal{U}(\alpha, A)$, form a submanifold of finite codimension $\leq n + n + n^2$, transverse to Λ . This co-dimension depends on the dimension of $\beta \in \mathbb{R}^n$ and the kernels of A and $[A, \cdot]$.

In many cases, it happens that the number of obstructions can be considerably decreased (see sections 2.1, 2.2, 2.3 and appendix B), depending on the particularity of the perturbation involved.

We start by giving the functional setting in which we will prove that the map

$$\phi : (g, u, \lambda) \mapsto g_* u + \lambda =: v$$

is a kind of local diffeomorphism, in the neighborhoods of $(\text{id}, u^0, 0)$ and u^0 .

1.2.1. Complex extensions. Let us extend the tori

$$\mathbb{T}^n = \mathbb{R}^n / 2\pi\mathbb{Z}^n \quad \text{and} \quad \mathbb{T}_0^n = \mathbb{T}^n \times \{0\} \subset \mathbb{T}^n \times \mathbb{R}^n,$$

as

$$\mathbb{T}_{\mathbb{C}}^n = \mathbb{C}^n / 2\pi\mathbb{Z}^n \quad \text{and} \quad \mathbb{T}_{\mathbb{C}}^n = \mathbb{T}_{\mathbb{C}}^n \times \mathbb{C}^n$$

respectively, and consider the corresponding s -neighborhoods defined using ℓ^∞ -balls (in the real normal bundle of the torus):

$$\mathbb{T}_s^n = \left\{ \theta \in \mathbb{T}_{\mathbb{C}}^n : \max_{1 \leq j \leq n} |\text{Im } \theta_j| \leq s \right\} \quad \text{and} \quad \mathbb{T}_s^n = \{(\theta, r) \in \mathbb{T}_{\mathbb{C}}^n : |(\text{Im } \theta, r)| \leq s\},$$

where $|(\text{Im } \theta, r)| := \max_{1 \leq j \leq n} \max(|\text{Im } \theta_j|, |r_j|)$.

Let now $f : \mathbb{T}_s^n \rightarrow \mathbb{C}$ be holomorphic, and consider its Fourier expansion $f(\theta, r) = \sum_{k \in \mathbb{Z}^n} f_k(r) e^{i k \cdot \theta}$, noting $k \cdot \theta = k_1 \theta_1 + \dots + k_n \theta_n$. In this context we introduce the so called "weighted norm":

$$|f|_s := \sum_{k \in \mathbb{Z}^n} |f_k| e^{|k|s}, \quad |k| = |k_1| + \dots + |k_n|,$$

$|f_k| = \sup_{|r| < s} |f_k(r)|$. Whenever $f : \mathbb{T}_s^n \rightarrow \mathbb{C}^n$, $|f|_s = \max_{1 \leq j \leq n} (|f_j|_s)$, f_j being the j -th component of $f(\theta, r)$.

It is a trivial fact that the classical sup-norm is bounded from above by the weighted norm:

$$\sup_{z \in \mathbb{T}_s^n} |f(z)| \leq |f|_s$$

and that $|f|_s < +\infty$ whenever f is analytic on its domain, which necessarily contains some $\mathbb{T}_{s'}^n$ with $s' > s$. In addition, the following useful inequalities hold if f, g are analytic on $\mathbb{T}_{s'}^n$

$$|f|_s \leq |f|_{s'}, \text{ for } 0 < s < s',$$

and

$$|fg|_{s'} \leq |f|_{s'} |g|_{s'}.$$

For more details about the weighted norm, see for example [Mey75], [Gio03] or [Chi03].

In general for complex extensions U_s and $V_{s'}$ of $\mathbb{T}^n \times \mathbb{R}^n$, we will denote $\mathcal{A}(U_s, V_{s'})$ the set of holomorphic functions from U_s to $V_{s'}$ and $\mathcal{A}(U_s)$, endowed with the s -weighted norm, the Banach space $\mathcal{A}(U_s, \mathbb{C})$.

Eventually, let E and F be two Banach spaces,

- We indicate contractions with a dot " \cdot ", with the convention that if $l_1, \dots, l_{k+p} \in E^*$ and $x_1, \dots, x_p \in E$

$$(l_1 \otimes \dots \otimes l_{k+p}) \cdot (x_1 \otimes \dots \otimes x_p) = l_1 \otimes \dots \otimes l_k \langle l_{k+1}, x_1 \rangle \dots \langle l_{k+p}, x_p \rangle.$$

In particular, if $l \in E^*$, we simply note $l^n = l \otimes \dots \otimes l$.

- If f is a differentiable map between two open sets of E and F , $f'(x)$ is considered as a linear map belonging to $F \otimes E^*$, $f'(x) : \zeta \mapsto f'(x) \cdot \zeta$; the corresponding norm will be the standard operator norm

$$|f'(x)| = \sup_{\zeta \in E, |\zeta|_E=1} |f'(x) \cdot \zeta|_F.$$

1.2.2. Space of conjugacies. We define \mathcal{G}_s^σ as the subspace of $\mathcal{A}(\mathbb{T}_s^n, \mathbb{T}_{\mathbb{C}}^n)$ consisting of maps of the form

$$g(\theta, r) = (\varphi(\theta), R_0(\theta) + R_1(\theta) \cdot r),$$

where

- the function φ belongs to $\mathcal{A}(\mathbb{T}_s^n, \mathbb{T}_{\mathbb{C}}^n)$ and is such that $\varphi(0) = 0$ and

$$|\varphi - \text{id}|_s < \sigma,$$

where $\varphi - \text{id}$ is considered as going from \mathbb{T}_s^n to \mathbb{C}^n ,

- $R_0 \in \mathcal{A}(\mathbb{T}_s^n, \mathbb{C}^n)$ and $R_1 \in \mathcal{A}(\mathbb{T}_s^n, \text{Mat}_n(\mathbb{C}))$ satisfy

$$|R_0(\theta) + R_1(\theta) \cdot r - r|_s < \sigma.$$

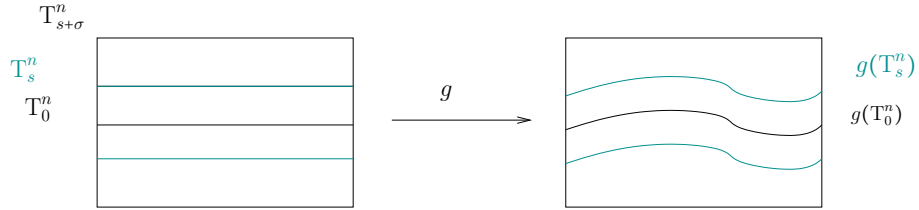

FIGURE 2. Deformed complex domain

The "Lie Algebra" $T_{\text{id}}\mathcal{G}_s^\sigma$ of \mathcal{G}_s^σ , consists of maps

$$\dot{g}(\theta, r) = (\dot{\varphi}(\theta), \dot{R}_0(\theta) + \dot{R}_1(\theta) \cdot r).$$

Here \dot{g} lies in $\mathcal{A}(\mathbb{T}_s^n, \mathbb{C}^{2n})$; more specifically $\dot{\varphi} \in \mathcal{A}(\mathbb{T}_s^n, \mathbb{C}^n)$, $\dot{R}_0 \in \mathcal{A}(\mathbb{T}_s^n, \mathbb{C}^n)$ and $\dot{R}_1 \in \mathcal{A}(\mathbb{T}_s^n, \text{Mat}_n(\mathbb{C}))$. We endow this space too with the norm

$$|\dot{g}|_s = \max_{1 \leq j \leq 2n} (|\dot{g}_j(\theta, r)|_s).$$

1.2.3. Spaces of vector fields. We define

- $\mathcal{V}_s = \mathcal{A}(\mathbb{T}_s^n, \mathbb{C}^{2n})$, endowed with the norm

$$|v|_s := \max_{1 \leq j \leq 2n} (|v_j(\theta, r)|_s),$$

and $\mathcal{V} = \bigcup_s \mathcal{V}_s$.

- For $\alpha \in \mathbb{R}^n$ and $A \in \text{Mat}_n \mathbb{R}$, $\mathcal{U}_s(\alpha, A)$ is the subspace of \mathcal{V}_s consisting of vector fields in the form

$$u(\theta, r) = (\alpha + O(r), A \cdot r + O(r^2)).$$

Finally, for a given isomorphism $g \in \mathcal{G}_s^\sigma$, we define as

$$|v|_{g,s} := |g^*v|_s$$

a "deformed" norm depending on g , the notation g^* standing for the pull-back of v : this in order not to shrink artificially the domains of analyticity. The problem, in a smooth context, may be solved without changing the domain, by using plateau functions.

1.2.4. The normal form operator ϕ . According to theorem C.1 and corollary C.1.1, the operators

$$(1.9) \quad \phi : \mathcal{G}_{s+\sigma}^{\sigma/n} \times \mathcal{U}_{s+\sigma}(\alpha, A) \times \Lambda \rightarrow \mathcal{V}_s, (g, u, \lambda) \mapsto g_* u + \lambda,$$

$g_* u = (g' \cdot u) \circ g^{-1}$, are now defined. Since these operators commute with source and target spaces, we will refer to them in the singular.

We will always assume that $0 < s < s + \sigma < 1$ and $\sigma < s$.

In the following we do not intend to be optimal.

1.2.5. Cohomological equations. Here we present three derivation operators and see how to solve the three associated cohomological equations; we will encounter equations of this type when trying to straighten the tangent and normal dynamics to the torus.

We make explicit the three conditions on small divisors we need to prove our lemmata, which all follow from (1.5).

$$(1.10) \quad |k \cdot \alpha| \geq \frac{\gamma}{|k|^\tau}, \quad \forall k \in \mathbb{Z}^n \setminus \{0\}$$

$$(1.11) \quad |ik \cdot \alpha + a_j| \geq \frac{\gamma}{(1 + |k|)^\tau}, \quad \forall k \in \mathbb{Z}^n, j = 1, \dots, n,$$

$$(1.12) \quad |ik \cdot \alpha + l \cdot a| \geq \frac{\gamma}{(1 + |k|)^\tau}, \quad \forall (k, l) \in \mathbb{Z}^n \times \mathbb{Z}^n \setminus \{0\}, \quad |l| = 2,$$

for $\alpha \in \mathbb{R}^n$ and $a = (a_1, \dots, a_n)$ being the vector of eigenvalues of a matrix $A \in \text{Mat}_n(\mathbb{R})$.

Let us consider a constant vector field $\alpha = (\alpha_1, \dots, \alpha_n)$ on \mathbb{T}_s^n , identified with a vector $\alpha \in \mathbb{R}^n$ and the Lie derivative operator associated to it

$$(1.13) \quad L_\alpha : \mathcal{A}(\mathbb{T}_{s+\sigma}^n) \rightarrow \mathcal{A}(\mathbb{T}_s^n), \quad f \mapsto L_\alpha f = f' \cdot \alpha := \sum_{j=1}^n \alpha_j \frac{\partial f}{\partial \theta_j},$$

f being an analytic function on $\mathbb{T}_{s+\sigma}^n$ with values in \mathbb{C} .

The following result holds:

LEMMA 1.2.1 (Straightening dynamics on the torus). *Let $\alpha \in \mathbb{R}^n$ be (γ, τ) -Diophantine and let $0 < s < s + \sigma$. For every $g \in \mathcal{A}(\mathbb{T}_{s+\sigma}^n, \mathbb{C})$ having zero average on the torus, there exists a unique preimage $f \in \mathcal{A}(\mathbb{T}_s^n, \mathbb{C})$ of zero average such that*

$$L_\alpha f = g;$$

moreover, the following estimate holds

$$|f|_s = |L_\alpha^{-1} g|_s \leq \frac{C_1}{\gamma} \frac{1}{\sigma^{n+\tau}} |g|_{s+\sigma},$$

C_1 being a constant depending only on the dimension n and the exponent τ .

PROOF. Let

$$g(\theta) = \sum_{k \in \mathbb{Z}^n \setminus \{0\}} g_k e^{i k \cdot \theta},$$

be the Fourier expansion of g . Coefficients g_k decay exponentially:

$$|g_k| = \left| \int_{\mathbb{T}^n} g(\theta) e^{-i k \cdot \theta} \frac{d\theta}{2\pi} \right| \leq |g|_{s+\sigma} e^{-|k|(s+\sigma)},$$

obtaining the inequality by deforming the path of integration to $\text{Im } \theta_j = -\text{sgn}(k_j)(s+\sigma)$. Expanding the term $L_\alpha f$ too, we see that a formal solution of $L_\alpha f = g$ is given by

$$(1.14) \quad f = \sum_{k \in \mathbb{Z}^n \setminus \{0\}} \frac{g_k}{i k \cdot \alpha} e^{i k \cdot \theta}.$$

Taking into account Diophantine condition (1.10) we have

$$\begin{aligned} |f|_s &\leq \frac{|g|_{s+\sigma}}{\gamma} \sum_k |k|^\tau e^{-|k|\sigma} \\ &\leq \frac{2^n |g|_{s+\sigma}}{\gamma} \sum_{\ell \geq 1} \binom{\ell+n+1}{\ell} e^{-\ell\sigma} \ell^\tau \\ &\leq \frac{4^n |g|_{s+\sigma}}{\gamma(n-1)!} \sum_{\ell \geq 1} (n+\ell-1)^{n-1+\tau} e^{-\ell\sigma} \\ &\leq \frac{4^n |g|_{s+\sigma}}{\gamma(n-1)!} \int_1^\infty (\ell+n-1)^{n+\tau-1} e^{-(\ell-1)\sigma} d\ell. \end{aligned}$$

The integral is equal to

$$\begin{aligned} &\sigma^{-\tau-n} e^{n\sigma} \int_{n\sigma}^\infty \ell^{\tau+n-1} e^{-\ell} d\ell \\ &< \sigma^{-\tau-n} e^{n\sigma} \int_0^\infty \ell^{\tau+n-1} e^{-\ell} d\ell = \sigma^{-\tau-n} e^{n\sigma} \Gamma(\tau+n). \end{aligned}$$

Hence $f \in \mathcal{A}(\mathbb{T}_s^n)$ and satisfies the claimed estimate. \square

Let

$$(1.15) \quad L_\alpha + A : \mathcal{A}(\mathbb{T}_{s+\sigma}^n, \mathbb{C}^n) \rightarrow \mathcal{A}(\mathbb{T}_s^n, \mathbb{C}^n), \quad f \mapsto L_\alpha f + A \cdot f = f' \cdot \alpha + A \cdot f.$$

The following result holds

LEMMA 1.2.2 (Relocating the torus). *Let $\alpha \in \mathbb{R}^n$ and $A \in \text{Mat}_n(\mathbb{R})$ be a diagonalizable matrix satisfying the Diophantine condition (1.11). For every $g \in \mathcal{A}(\mathbb{T}_{s+\sigma}^n, \mathbb{C}^n)$, there exists a unique preimage $f \in \mathcal{A}(\mathbb{T}_s^n, \mathbb{C}^n)$ by $L_\alpha + A$. Moreover the following estimate holds*

$$|f|_s = |(L_\alpha + A)^{-1} g|_s \leq \frac{C_2}{\gamma} \frac{1}{\sigma^{n+\tau}} |g|_{s+\sigma},$$

C_2 being a constant depending only on the dimension n and the exponent τ .

PROOF. Let us start for simplicity with the scalar case $g \in \mathcal{A}(\mathbb{T}_{s+\sigma}^n)$ and $A = a \neq 0 \in \mathbb{R}$. Expanding both sides of $L_\alpha f + a \cdot f = g$ we see that the Fourier coefficients of the formal preimage f is given by

$$f_k = \frac{g_k}{ik \cdot \alpha + a},$$

hence

$$(1.16) \quad f = (L_\alpha + a)^{-1}g = \sum_{k \in \mathbb{Z}^n} \frac{g_k}{ik \cdot \alpha + a} e^{ik \cdot \theta}.$$

Taking now into account the Diophantine condition and doing the same sort of calculations as in Lemma 1.2.1, we get the wanted estimate.

The case where A is a diagonal matrix can be recovered from the scalar one just by noticing that to $g(\theta) = (g^1(\theta), \dots, g^n(\theta))$ corresponds a preimage $f(\theta) = (f^1(\theta), \dots, f^n(\theta))$ whose components read like in the scalar case.

When A is diagonalizable, let $P \in \text{GL}_n(\mathbb{R})$ such that PAP^{-1} is diagonal. Considering $f' \cdot \alpha + A \cdot f = g$, and left multiplying both sides by P , we get

$$\tilde{f}' \cdot \alpha + PAP^{-1} \tilde{f} = \tilde{g},$$

where we have set $\tilde{g} = Pg$ and $\tilde{f} = Pf$. This equation has a unique solution with the wanted estimates. We just need to put $f = P^{-1} \tilde{f}$. \square

Finally, consider an analytic function F on $\mathbb{T}_{s+\sigma}^n$ with values in $\text{Mat}_n(\mathbb{C})$. Define the operator

$$(1.17) \quad \begin{array}{ccc} L_\alpha + [A, \cdot] : & \mathcal{A}(\mathbb{T}_{s+\sigma}^n, \text{Mat}_n(\mathbb{C})) & \rightarrow \mathcal{A}(\mathbb{T}_s^n, \text{Mat}_n(\mathbb{C})) \\ F & & \mapsto L_\alpha F + [A, F] \end{array},$$

where the notation $L_\alpha F$ means that we are applying the Lie derivative operator to each component of the matrix F (read $((L_\alpha F_j^i)_j^i)$ if the components notation for matrices results clearer), and $[A, F]$ is the usual commutator. We have the following

LEMMA 1.2.3 (Straighten the first order dynamics). *Let $\alpha \in \mathbb{R}^n$ and $A \in \text{Mat}_n(\mathbb{R})$ be a diagonalizable matrix satisfying the Diophantine conditions (1.10) and (1.12) respectively. For every $G \in \mathcal{A}(\mathbb{T}_{s+\sigma}^n, \text{Mat}_n(\mathbb{C}))$, such that $\int_{\mathbb{T}^n} G_i^i \frac{d\theta}{(2\pi)^n} = 0$, there exists a unique $F \in \mathcal{A}(\mathbb{T}_s^n, \text{Mat}_n(\mathbb{C}))$, having zero average diagonal elements $\int_{\mathbb{T}^n} F_i^i \frac{d\theta}{(2\pi)^n} = 0$, such that the matrix equation*

$$L_\alpha F + [A, F] = G$$

is satisfied; moreover the following estimate holds

$$|F|_s \leq \frac{C_3}{\gamma} \frac{1}{\sigma^{n+\tau}} |G|_{s+\sigma},$$

C_3 being a constant depending only on the dimension n and the exponent τ .

PROOF. Let us start with the diagonal case. Let $A = \text{diag}(a_1, \dots, a_n)$ be diagonal and $F \in \text{Mat}_n(\mathbb{C})$ be given, the commutator $[A, F]$ reads

$$(1.18) \quad \begin{pmatrix} 0 & (a_1 - a_2)F_2^1 & (a_1 - a_3)F_3^1 & \dots & (a_1 - a_n)F_n^1 \\ (a_2 - a_1)F_1^2 & 0 & (a_2 - a_3)F_3^2 & \dots & (a_2 - a_n)F_n^2 \\ \vdots & \vdots & \vdots & \vdots & \vdots \\ (a_n - a_1)F_1^n & (a_n - a_2)F_2^n & \dots & \dots & 0 \end{pmatrix},$$

where we called F_j^i the element corresponding to the i -th line and j -th column of the matrix $F(\theta)$. Using components notation, the matrix reads

$$([A, F]_j^i) = ((a_i - a_j)F_j^i),$$

and shows all zeros along the diagonal. Adding it now up with the matrix $L_\alpha F$, which reads

$$(1.19) \quad \begin{pmatrix} L_\alpha F_1^1 & \dots & L_\alpha F_n^1 \\ \vdots & L_\alpha F_j^i & \vdots \\ L_\alpha F_1^n & \dots & L_\alpha F_n^n \end{pmatrix},$$

we see that to solve the equation $L_\alpha F + [A, F] = G$, G being given, we need to solve n equations of the type of Lemma 1.2.1 and $n^2 - n$ equations of the type of Lemma 1.2.2. Expanding every element in Fourier series, we see that the formal solution is given by a matrix F whose diagonal elements are of the form

$$F_j^j = \sum_{k \in \mathbb{Z}^n \setminus \{0\}} \frac{G_{j,k}^j}{ik \cdot \alpha} e^{ik \cdot \theta},$$

while the non diagonal are of the form

$$F_j^i = \sum_{k \in \mathbb{Z}^n} \frac{G_{j,k}^i}{ik \cdot \alpha + (a_i - a_j)} e^{ik \cdot \theta}.$$

By conditions (1.10)-(1.12), via the same kind of calculations we did in the previous lemmata, we get the wanted estimate.

Eventually, to recover the general case, we consider the transition matrix $P \in \text{GL}_n(\mathbb{R})$ and the equation

$$L_\alpha(PFP^{-1}) + P[A, F]P^{-1} = PGP^{-1},$$

and observe that we can see $P[A, F]P^{-1}$ as

$$P[A, F]P^{-1} = PAP^{-1}PFP^{-1} - PFP^{-1}PAP^{-1} = [PAP^{-1}, PFP^{-1}].$$

Letting $\tilde{F} = PFP^{-1}$ and $\tilde{G} = PGP^{-1}$, \tilde{F} satisfies the wanted estimates, and $G = P^{-1}\tilde{G}P$. \square

We address the reader looking for optimal estimates to the paper of Rüssmann [Rüs75].

1.3. Estimates on ϕ'^{-1} and ϕ''

The problem is: v being given, find g, u and λ such that the following holds

$$(1.20) \quad g_* u + \lambda = v.$$

The aim of the following sections is to prove the following theorem, from which Moser's theorem 1.2 follows.

Let us fix $u^0 \in \mathcal{U}_s(\alpha, A)$ and note $\mathcal{V}_{s+\sigma}^\sigma = \{v \in \mathcal{V} : |v - u^0|_s < \sigma\}$ the ball of radius σ centered at u^0 .

THEOREM 1.3. *The operator ϕ is a local diffeomorphism in the sense that for every $s < s + \sigma < 1$ there exist $\varepsilon > 0$ and a unique C^∞ -map ψ*

$$\psi : \mathcal{V}_{s+\sigma}^\varepsilon \rightarrow \mathcal{G}_s \times \mathcal{U}_s(\alpha, A) \times \Lambda$$

such that $\phi \circ \psi = \text{id}$.

To shorten notations we sometimes call $x_0 = (\text{id}, u^0, 0)$.

In order to solve locally $\phi(x) = y$, we use the remarkable idea of Kolmogorov and find the solution by composing infinitely many times the operator

$$x \mapsto x + \phi'^{-1}(x)(y - \phi(x)),$$

on extensions $\mathbb{T}_{s+\sigma}^n$ of shrinking width.

To control the convergence of the iterates it is necessary that ϕ'^{-1} do exist in a whole neighborhood of x_0 and that ϕ'^{-1} and ϕ'' satisfy a suitable estimate. Let us start to check the existence of a right inverse for

$$\phi'(g, u, \lambda) : T_g \mathcal{G}_{s+\sigma}^{\sigma/n} \times \vec{\mathcal{U}}_{s+\sigma} \times \Lambda \rightarrow \mathcal{V}_{g,s},$$

if g is close to id . We denoted by $\vec{\mathcal{U}}_{s+\sigma}$ the vector space directing $\mathcal{U}(\alpha, A)$.

We make the following identifications

$$\begin{array}{ccccc}
 & & g' & & \\
 & \curvearrowright & & \curvearrowleft & \\
 T(\mathbb{T}_{\mathbb{C}}^n \times \mathbb{C}^n) & \xleftrightarrow{\sim} & g^* T(\mathbb{T}_{\mathbb{C}}^n \times \mathbb{C}^n) & \xleftrightarrow{\sim} & T(\mathbb{T}_{\mathbb{C}}^n \times \mathbb{C}^n) \\
 & \swarrow \dot{g} & & \searrow \delta g & \uparrow \delta g \circ g^{-1} \\
 & & \mathbb{T}_{\mathbb{C}}^n \times \mathbb{C}^n & \xrightarrow{g} & \mathbb{T}_{\mathbb{C}}^n \times \mathbb{C}^n
 \end{array}$$

where $\dot{g} = g^*(\delta g \circ g^{-1}) = g'^{-1} \cdot \delta g$. In addition, we see sections of $T(\mathbb{T}_{\mathbb{C}}^n \times \mathbb{C}^n)$ as elements of $\mathcal{A}(\mathbb{T}_{\mathbb{C}}^n \times \mathbb{C}^n, \mathbb{C}^{2n})$.

PROPOSITION 1.3.1. *There exists ε_0 such that if (g, u, λ) are in $\mathcal{G}_{s+\sigma}^{\varepsilon_0} \times \mathcal{U}_{s+\sigma}(\alpha, A) \times \Lambda$ then for every δv in $\mathcal{V}_{g, s+\sigma}$ there exists a unique triplet $(\delta g, \delta u, \delta \lambda) \in T_g \mathcal{G}_s \times \vec{\mathcal{U}}_s \times \Lambda$ such that*

$$(1.21) \quad \phi'(g, u, \lambda) \cdot (\delta g, \delta u, \delta \lambda) = \delta v;$$

moreover, we have the following estimate

$$(1.22) \quad \max(|\delta g|_s, |\delta u|_s, |\delta \lambda|) \leq \frac{C}{\sigma^{\tau'}} |\delta v|_{g, s+\sigma},$$

$\tau' > 1$ and C being a constant that depends only on $|g|_{s+\sigma}$ and $|u|_{s+\sigma}$.

PROOF. Let a vector field δv in $\mathcal{V}_{g, s+\sigma}$ be given, we want to invert

$$\phi'(g, u, \lambda) \cdot (\delta g, \delta u, \delta \lambda) = \delta v.$$

Calculating¹ explicitly the left hand side of the equation, we get

$$(1.23) \quad [g_* u, \delta g \circ g^{-1}] + g_* \delta u + \delta \lambda = \delta v.$$

Both sides are supposed to belong to $\mathcal{V}_{g, s+\sigma}$; in order to solve the equation we pull it back, using the naturality of the Lie bracket with respect to the pull-back operator, thus obtaining the equivalent system in $g^* \mathcal{V}_{s+\sigma}$

$$(1.24) \quad [u, g^* \delta g \circ g^{-1}] + \delta u + g^* \delta \lambda = g^* \delta v.$$

To lighten the notation we baptize the new terms as

$$\dot{\lambda} := g^* \delta \lambda, \quad \dot{v} := g^* \delta v,$$

and read

$$(1.25) \quad [u, \dot{g}] + \delta u + \dot{\lambda} = \dot{v}.$$

The unknowns are now $\dot{g}, \delta u$ and $\dot{\lambda}$; the new infinitesimal vector field of counter terms $\dot{\lambda}$ is no more constant in general, on the other hand, we can take advantage of u in its "straight" form.

Let us expand the vector fields along $\mathbb{T}_{s+\sigma}^n \times \{0\}$; we obtain

$$\begin{cases} u(\theta, r) = (\alpha + u_1(\theta) \cdot r + O(r^2), A \cdot r + U_2(\theta) \cdot r^2 + O(r^3)) \\ \dot{g}(\theta, r) = (\dot{\varphi}(\theta), \dot{R}_0(\theta) + \dot{R}_1(\theta) \cdot r) \\ \dot{\lambda}(\theta, r) = (\dot{\lambda}_0(\theta), \dot{\Lambda}_0(\theta) + \dot{\Lambda}_1(\theta) \cdot r) \\ \dot{v}(\theta, r) = (\dot{v}_0(\theta) + O(r), \dot{V}_0(\theta) + \dot{V}_1(\theta) \cdot r + O(r^2)). \end{cases}$$

We are interested in normalizing the dynamics tangentially at the order zero with respect to r , while up to the first order in the normal direction; we then consider the "mixed jet" :

$$j^{0,1} \dot{v} = (\dot{v}_0(\theta), \dot{V}_0(\theta) + \dot{V}_1(\theta) \cdot r).$$

¹See Appendix.

Using the expression

$$[u, \dot{g}] = (\dot{\varphi}' \cdot \alpha - u_1 \cdot \dot{R}_0 + O(r^2)) \frac{\partial}{\partial \theta} + (\dot{R}'_0 \cdot \alpha - A \cdot \dot{R}_0 + ([A, \dot{R}_1] + \dot{R}'_1 \cdot \alpha + \dot{R}'_0 \cdot u_1 - 2U_2 \cdot \dot{R}_0) \cdot r + O(r^2)) \frac{\partial}{\partial r};$$

and identifying terms of the same order in (1.25), yields

$$(1.26) \quad \dot{\varphi}' \cdot \alpha - u_1 \cdot \dot{R}_0 = \dot{v}_0 - \dot{\lambda}_0,$$

$$(1.27) \quad \dot{R}'_0 \cdot \alpha - A \cdot \dot{R}_0 = \dot{V}_0 - \dot{\Lambda}_0,$$

$$(1.28) \quad [A, \dot{R}_1] + \dot{R}'_1 \cdot \alpha + \dot{R}'_0 \cdot u_1 - 2U_2 \cdot \dot{R}_0 = \dot{V}_1 - \dot{\Lambda}_1,$$

where the first equation concerns the tangent direction and (1.27)-(1.28) the normal direction. This is a triangular system that, starting from (1.27), we are able to solve; actually these equations are of the same type as the ones we already solved in Lemmata 1.2.1-1.2.2-1.2.3 (in the sense of their projection on the image of the operator $[u, \dot{g}]$).

We remark that since $\delta u = (O(r), O(r^2))$, $j^{0,1} \delta u = 0$ and δu has no contribution to the previous equations. Once we have solved them, we will determine δu identifying the reminders.

REMARK 1.2. Every equation contains two unknowns: the components of \dot{g} and $\dot{\lambda}$, and the given \dot{v} . We start to solve equations modulo $\dot{\lambda}$, eventually $\delta \lambda$ will be uniquely chosen to kill the component of the right hand side belonging to the kernel of $[u, \dot{g}]$ (i.e. the constant part of the given terms in (1.26)-(1.27)-(1.28) belonging to the kernel of A and $[A, \cdot]$ respectively), and solve the cohomological equations.

Let us proceed with solving the system. We are going to repeatedly apply lemmata 1.2.1-1.2.2-1.2.3 and Cauchy's inequality.

First, consider (1.27). Defining $\bar{b} = \int_{\mathbb{T}^n} \dot{V}_0 - \dot{\Lambda}_0 \frac{d\theta}{(2\pi)^n}$, we have

$$\dot{R}_0 = (L_\alpha + A)^{-1} (\dot{V}_0 - \dot{\Lambda}_0 - \bar{b}),$$

and

$$|\dot{R}_0|_s \leq \frac{C_2}{\gamma} \frac{1}{\sigma^{n+\tau}} |\dot{V}_0 - \dot{\Lambda}_0|_{s+\sigma}.$$

Secondly, consider equation (1.26). Calling the average

$$\bar{\beta} = \int_{\mathbb{T}^n} \dot{v}_0 + u_1 \cdot \dot{R}_0 - \dot{\lambda}_0 \frac{d\theta}{(2\pi)^n},$$

the solution reads

$$\dot{\varphi} = L_\alpha^{-1} (\dot{v}_0 + u_1 \cdot \dot{R}_0 - \dot{\lambda}_0 - \bar{\beta}),$$

with

$$|\dot{\varphi}|_{s-\sigma} \leq \frac{C_1}{\gamma} \frac{1}{\sigma^{n+\tau}} |\dot{v}_0 + u_1 \cdot \dot{R}_0 - \dot{\lambda}_0|_s.$$

Thirdly, the $\text{Mat}_m(\mathbb{R})$ -valued solution of (1.28) reads

$$\dot{R}_1 = (L_\alpha + [A, \cdot])^{-1} (\dot{V}_1 + \dot{\Lambda}_1 - \bar{B}),$$

having defined $\dot{\bar{V}}_1 = \dot{V}_1 - \dot{R}'_0 \cdot u_1 + 2U_2 \cdot \dot{R}_0$, \bar{B} being the average

$$\bar{B} = \int_{\mathbb{T}^n} \dot{V}_1 - \dot{R}'_0 \cdot u_1 + 2U_2 \cdot \dot{R}_0 - \dot{B} \frac{d\theta}{(2\pi)^n}.$$

Moreover, we have the following estimate

$$|\dot{R}_1|_{s-2\sigma} \leq \frac{C_3}{\gamma} \frac{1}{\sigma^{n+\tau+1}} |\dot{\bar{V}}_1 - \dot{\Lambda}_1|_{s+\sigma}.$$

It now remains to handle the choice of $\delta\lambda$ that makes equations average free. Consider the vector field $\bar{\lambda}(\theta, r) = (\bar{\beta}, \bar{b} + \bar{B} \cdot r)$, which consequently lays in Λ , and the map

$$F_g : \Lambda \rightarrow \Lambda, \quad \delta\lambda \mapsto -\bar{\lambda}.$$

When $g = \text{id}$, $F'_{\text{id}} = -\text{id}$. Provided that g stays sufficiently close to the identity, say ε_0 -close to the identity in $|\cdot|_{s_0}$ -norm ($s_0 < s < s + \sigma$), F' will be bounded away from 0. Note in particular that $-\lambda$ is affine in $\delta\lambda$, the system to solve being triangular of the form $\int_{\mathbb{T}^n} a(g, v) + A(g) \cdot \delta\lambda = 0$, with diagonal close to 1 if the smallness condition above is assumed. Hence there exists a unique $\delta\lambda$ such that $F_g(\delta\lambda) = 0$; we have

$$|\delta\lambda| \leq \frac{C_4}{\gamma \sigma^{\tilde{\tau}}} |\dot{v}|_{s+\sigma},$$

for some $\tilde{\tau} > 1$. We finally have

$$|\dot{g}|_{s-2\sigma} \leq \frac{C_5}{\gamma} \frac{1}{\sigma^{\tau'''}} |\delta v|_{g, s+\sigma}.$$

Remembering the definition of \dot{g} we have $\delta g = g' \cdot \dot{g}$, hence

$$|\delta g|_{s-2\sigma} \leq \sigma^{-1} (1 + |g - \text{id}|_{s+\sigma}) \frac{C_5}{\gamma} \frac{1}{\sigma^{\tau'''}} |\delta v|_{g, s+\sigma}.$$

Finally, we see that δu is actually well defined in $\vec{\mathcal{U}}_{s-2\sigma}$ and have

$$|\delta u|_{s-2\sigma} \leq \frac{C_6}{\gamma} \frac{1}{\sigma^{\tau'}}$$

Up to defining $\sigma' = \sigma/3$ and $s' = s + \sigma$, the proposition is proved for all indices s' and σ' with $s' < s' + \sigma'$.

□

REMARK 1.3. *In order to solve the linearized equation*

$$\phi'(g, u, \lambda) \cdot (\delta g, \delta u, \delta \lambda) = \delta v,$$

we pulled it back to live where dynamics is "straight". One may ask if everything would have worked the same if, instead of differentiating $\phi(g, u, \lambda)$ then passing through pull-back, we had before pulled $\phi(g, u, \lambda)$ back and then differentiate, that is, to show that

$$\Phi(g, u, \lambda; v) = u + g^*(\lambda - v) = 0$$

has an invertible differential. The problem is that the operator

$$\frac{\partial \Phi}{\partial(g, u, \lambda)}(g, u, \lambda; v) \cdot (\delta g, \delta u, \delta \lambda) = [g^*(\lambda - v), g'^{-1} \cdot \delta g] + g^* \delta \lambda + \delta u$$

is not invertible in a whole neighborhood of $(\text{id}, u^0, 0, u^0)$: if $g^(\lambda - v)$ is just Liouville or resonant, the operator is not surjective and this compromises to perform repeatedly a Newton-like scheme. This issue was pointed out by Zehnder in [Zeh75], in which he shows that invertibility holds in a neighborhood of $\Phi = 0$ only up to a second order term. Zehnder tackles the problem by constructing an approximate right inverse. The operations of pull-back and differentiate do not commute. Zehnder's proof and our proof correspond to the two possible paths.*

1.3.1. Second derivative.

LEMMA 1.3.1 (Bounding ϕ''). *Let ϕ be the normal form operator previously defined. Its second derivative*

$$\phi''(g, u, \lambda) : (T_g \mathcal{G}_{s+\sigma}^\sigma \times \vec{\mathcal{U}}_{s+\sigma} \times \Lambda)^{\otimes 2} \rightarrow \mathcal{V}_s,$$

satisfies the following estimate

$$|\phi''(g, u, \lambda)(\delta g, \delta u, \delta \lambda)^{\otimes 2}|_{g,s} \leq \frac{C''}{\sigma^{\tau''}} |(\delta g, \delta u, \delta \lambda)|_{s+\sigma}^2,$$

C'' being a constant depending on $|g|_{s+\sigma}$ and $|u|_{s+\sigma}$.

PROOF. For simplicity call $x = (g, u, \lambda)$ and $\delta x = (\delta g, \delta u, \delta \lambda)$. Recall the expression of $\phi'(x) \cdot \delta x = [g_* u, \delta g \circ g^{-1}] + g_* \delta u + \delta \lambda$. Differentiating again with respect to x yields

$$\begin{aligned} - ([g_* u, \delta g \circ g^{-1}])' &= [[g_* u, \delta g \circ g^{-1}] + g_* \delta u, \delta g \circ g^{-1}] - [g_* u, \delta g' \circ g^{-1} \cdot \delta g^{-1}] \\ - (g_* \delta u)' &= [g_* \delta u, \delta g \circ g^{-1}] \\ - (\delta \lambda)' &= 0; \end{aligned}$$

recalling that $\delta g^{-1} = -(g'^{-1} \cdot \delta g) \circ g^{-1}$,

$$g^* \phi''(x) \delta x^{\otimes 2} = 2[\delta u, \dot{g}] + [[u, \dot{g}], \dot{g}] + [u, g^* (\delta g' \cdot g'^{-1} \cdot \delta g) \circ g^{-1}],$$

where the last term simplifies in

$$[u, g'^{-1} \cdot (\delta g' \cdot g'^{-1} \cdot \delta g)].$$

the wanted bound follows from repeatedly applying Cauchy's inequality, triangular inequality and Lemma D.2.1. \square

1.4. The abstract inverse function theorem

We present here the inverse function theorem we use to prove theorem 1.3. We follow [Féj12].

Consider two decreasing families of Banach spaces $(E_s, |\cdot|_s)$ and $(F_s, |\cdot|_s)$, $0 < s < 1$ carrying increasing norms $|\cdot|_s$ and let $B_s^E(\sigma) = \{x \in E : |x|_s < \sigma\}$ be the ball of radius σ centered at 0 in E_s .

We additionally endow $(F_s)_{s>0}$ with some deformed norms which depend on $x \in B_s^E(s)$ such that

$$|y|_{0,s} = |y|_s \quad \text{and} \quad |y|_{\hat{x},s} \leq |y|_{x,s+|x-\hat{x}|_s}.$$

Consider then operators commuting with inclusions $\phi : B_{s+\sigma}^E(\sigma) \rightarrow F_s$, $0 < s < s + \sigma < 1$, such that $\phi(0) = 0$.

We then suppose that if $x \in B_{s+\sigma}^E(\sigma)$ then $\phi'(x) : E_{s+\sigma} \rightarrow F_s$ has a right inverse $\phi'^{-1}(x) : F_{s+\sigma} \rightarrow E_s$ (for the particular operators ϕ of this work, ϕ' is both left and right invertible).

ϕ is supposed to be at least twice differentiable.

Let $\tau := \tau' + \tau''$ and $C := C' C''$.

THEOREM 1.4. *Under the previous assumptions, assume*

$$(1.29) \quad |\phi'^{-1}(x) \delta y|_s \leq \frac{C'}{\sigma^{\tau'}} |\delta y|_{x,s+\sigma}$$

$$(1.30) \quad |\phi''(x) \delta x^{\otimes 2}|_{x,s} \leq \frac{C''}{\sigma^{\tau''}} |\delta x|_{s+\sigma}^2, \quad \forall s, \sigma : 0 < s < s + \sigma < 1$$

C' and C'' depending on $|x|_{s+\sigma}$, $\tau', \tau'' \geq 1$.

For any s, σ, η with $\eta < s$ and $\varepsilon \leq \eta \frac{\sigma^{2\tau}}{2^{8\tau} C^2}$ ($C \geq 1, \sigma < 3C$), ϕ has a right inverse $\psi : B_{s+\sigma}^F(\varepsilon) \rightarrow B_s^E(\eta)$. In other words, ϕ is locally surjective:

$$B_{s+\sigma}^F(\varepsilon) \subset \phi(B_s^E(\eta)).$$

Define

$$(1.31) \quad Q : B_{s+2\sigma}^E(\sigma) \times B_{s+2\sigma}^E \rightarrow F_s, \quad (x, \hat{x}) \mapsto \phi(\hat{x}) - \phi(x) - \phi'(x)(\hat{x} - x),$$

the reminder of the Taylor formula.

LEMMA 1.4.1. *For every x, \hat{x} such that $|x - \hat{x}|_s < \sigma$,*

$$(1.32) \quad |Q(x, \hat{x})|_{x,s} \leq \frac{C''}{2\sigma^2} |\hat{x} - x|_{s+\sigma+|\hat{x}-x|_s}^2.$$

PROOF. Let $x_t = (1-t)x + t\hat{x}$, $0 \leq t \leq 1$, be the segment joining x to \hat{x} . Using Taylor's formula,

$$Q(x, \hat{x}) = \int_0^1 (1-t)\phi''(x_t)(\hat{x} - x)^2 dt,$$

hence

$$\begin{aligned} |Q(x, \hat{x})|_{x,s} &\leq \int_0^1 (1-t)|\phi''(x_t)(\hat{x} - x)^2|_{x,s} dt \\ &\leq \int_0^1 (1-t)|\phi''(x_t)(\hat{x} - x)^2|_{x_t, s+|x_t-x|_s} dt \\ &\leq \int_0^1 (1-t) \frac{C''}{\sigma^2} |(\hat{x} - x)|_{s+\sigma+|x_t-x|_s}^2 dt \\ &\leq \frac{C''}{2\sigma^2} |\hat{x} - x|_{s+\sigma+|\hat{x}-x|_s}^2. \end{aligned}$$

□

We are now ready to prove Theorem 1.4.

PROOF. Let s, σ, η , with $\eta < s < 1$ be fixed positive real numbers. Let also $y \in B_{s+\sigma}^F(\varepsilon)$, for some $\varepsilon > 0$. We define the following map:

$$f : B_{s+\sigma}^E(\sigma) \rightarrow E_s, \quad x \mapsto x + \phi'^{-1}(x)(y - \phi(x)).$$

We want to prove that, if ε is sufficiently small, there exists a sequence defined by induction by

$$\begin{cases} x_0 = 0 \\ x_{n+1} = f(x_n), \end{cases}$$

converging towards some point $x \in B_s^E(\eta)$, a preimage of y by ϕ .

Let us introduce two sequences

- a sequence of positive real numbers $(\sigma_n)_{n \geq 0}$ such that $3 \sum_n \sigma_n = \sigma$ be the total width of analyticity we will have lost at the end of the algorithm,
- the decreasing sequence $(s_n)_{n \geq 0}$ defined inductively by $s_0 = s + \sigma$ (the starting width of analyticity), $s_{n+1} = s_n - 3\sigma_n$. Of course, $s_n \rightarrow s$ when $n \rightarrow +\infty$.

Suppose now the existence of x_0, \dots, x_{n+1} .

From $x_k - x_{k-1} = \phi'^{-1}(x_{k-1})(y - \phi(x_{k-1}))$ we see that $y - \phi(x_k) = -Q(x_{k-1}, x_k)$, which permits to write $x_{k+1} - x_k = -\phi'^{-1}(x_k)Q(x_{k-1}, x_k)$, for $k = 1, \dots, n$.

Assuming that $|x_k - x_{k-1}|_{s_k} \leq \sigma_k$, for $k = 1, \dots, n$, from the estimate of the right inverse and the previous lemma we get

$$|x_{n+1} - x_n|_{s_{n+1}} \leq \frac{C}{2\sigma_n^\tau} |x_n - x_{n-1}|_{s_n}^2 \leq \dots \leq C_n C_{n-1}^2 \dots C_1^{2^{n-1}} |x_1 - x_0|_{s_1}^{2^n},$$

with $C_n = \frac{C}{2\sigma_n^\tau}$.

First, remark that

$$|x_1 - x_0|_{s_1} \leq \frac{C'}{(3\sigma_0)^\tau} |y - \phi(x_0)|_{s_0} \leq \frac{C}{2\sigma_0^\tau} |y|_{s+\sigma} \leq \frac{C}{2\sigma_0^\tau} \varepsilon.$$

Second, observe that if $C_k \geq 1$ (see remark below),

$$|x_{n+1} - x_n|_{s_{n+1}} \leq \left(\varepsilon \prod_{k \geq 0} C_k^{2^{-k}} \right)^{2^n}.$$

Third, note that

$$\sum_{n \geq 0} z^{2^n} = z + z^2 + z^4 + \dots \leq z \sum_{n \geq 0} z^n \leq 2z,$$

if $z \leq \frac{1}{2}$.

The key point is to choose ε such that $\varepsilon \prod_{k \geq 0} C_k^{2^{-k}} \leq \frac{1}{2}$ (or any positive number < 1) and $\sum_{n \geq 0} |x_{n+1} - x_n|_{s_{n+1}} < \eta$, in order for the whole sequence (x_k) to exist and converge in $B_s(\eta) \subset E_s$. Hence, using the definition of the C_n 's and the fact that

$$\left(\frac{C}{2} \right)^{-2^{-k}} = \left(\frac{2}{C} \right)^{\left(\frac{1}{2}\right)^k} \implies \prod \left(\frac{2}{C} \right)^{\left(\frac{1}{2}\right)^k} = \left(\frac{2}{C} \right)^{\sum \frac{1}{2^k}} = \left(\frac{2}{C} \right)^2,$$

within $\sum_k \frac{1}{2^k} = \sum_k k \frac{1}{2^k} = 2$, we obtain as a sufficient value

$$(1.33) \quad \varepsilon = \eta \frac{2}{C^2} \prod_{k \geq 0} \sigma_k^{\tau \left(\frac{1}{2}\right)^k}.$$

Eventually, the constraint $3 \sum_{n \geq 0} \sigma_n = \sigma$ gives $\sigma_k = \frac{\sigma}{6} \left(\frac{1}{2}\right)^k$, which, plugged into (1.33), gives:

$$\varepsilon = \eta \frac{2}{C^2} \left(\frac{\sigma}{12} \right)^{2\tau} > \frac{\sigma^{2\tau} \eta}{2^{8\tau} C^2},$$

hence the theorem.

A posteriori, the exponential decay we proved makes straightforward the further assumption $|x_k - x_{k-1}|_{s_k} < \sigma_k$ to apply lemma 1.4.1.

Concerning the bounds over the constant C , as $\sum_k |x_{k+1} - x_k|_{s_{k+1}} \leq \eta$, we see that all the $|x_n|_{s_n}$ are bounded, hence the constants C' and C'' depending on them.

Moreover, to have all the $C_n \geq 1$, as we previously supposed, it suffices to assume $C \geq \sigma/3$. \square

REMARK 1.4. *In the case the operator ϕ is defined only on polynomially small balls*

$$\phi : B_{s+\sigma}^E(c_0\sigma^\ell) \rightarrow F_s, c_0 > 0, \forall s, \sigma$$

the statement and the proof of theorem 1.4 still hold, provided that η is chosen small enough ($\eta < 2c_0(\sigma/12)^\ell$ suffices).

This will be the case of the operators defined in the next chapter, where $\ell = 2$.

We want to show the uniqueness and some regularity properties of the right inverse ψ of ϕ , assuming the additional left invertibility of ϕ' (which is the case, for the particular operator ϕ' of interest to us).

First, a definition is needed,

DEFINITION 1.4.1. *We will say that a family of norms $(|\cdot|_s)_{s>0}$ on a grading $(E_s)_{s>0}$ is log-convex if for every $x \in E_s$ the map $s \mapsto \log|x|_s$ is convex.*

LEMMA 1.4.2. *If $(|\cdot|_s)$ is log-convex, the following inequality holds*

$$|x|_{s+\sigma}^2 \leq |x|_s |x|_{s+\tilde{\sigma}}, \quad \forall s, \sigma, \tilde{\sigma} = \sigma(1 + \frac{1}{s}).$$

PROOF. If $f : s \mapsto \log|x|_s$ is convex, this inequality holds

$$f\left(\frac{s_1 + s_2}{2}\right) \leq \frac{f(s_1) + f(s_2)}{2}.$$

Let now $x \in E_s$, then

$$\log|x|_{s+\sigma} \leq \log|x|_{\frac{2s+\tilde{\sigma}}{2}} \leq \frac{1}{2}(\log|x|_s + \log|x|_{s+\tilde{\sigma}}) = \frac{1}{2}\log(|x|_s|x|_{s+\tilde{\sigma}}),$$

hence the lemma. □

Let us assume that the family of norms $(|\cdot|_s)_{s>0}$ of the grading $(E_s)_{s>0}$ are log-convex, which is the case for our choice of norms (see end of Moser's proof). To prove the uniqueness of ψ we are going to assume that ϕ' is also left-invertible (remember proposition 1.3.1).

PROPOSITION 1.4.1 (Lipschitz continuity of ψ). *Let $\sigma < s$. If $y, \hat{y} \in B_{s+\sigma}^F(\varepsilon)$ with $\varepsilon = 3^{-4\tau}2^{-16\tau}\frac{\sigma^{6\tau}}{4C^3}$, the following inequality holds*

$$|\psi(y) - \psi(\hat{y})|_s \leq L|y - \hat{y}|_{x, s+\sigma},$$

with $L = 2C'/\sigma^{\tau'}$. In particular, ψ being the unique local right inverse of ϕ , it is also its unique left inverse.

PROOF. In order to get the wanted estimate we introduce an intermediate parameter ξ , that will be chosen later, such that $\eta < \xi < \sigma < s < s + \sigma$. To lighten notations let us call $\psi(y) =: x$ and $\psi(\hat{y}) =: \hat{x}$. Let also $\varepsilon = \frac{\xi^{2\tau}\eta}{2^{3\tau}C^2}$ so that if $y, \hat{y} \in B_{s+\sigma}^F(\varepsilon)$, $x, \hat{x} \in B_{s+\sigma-\xi}^E(\eta)$, by theorem 1.4, provided that $\eta < s + \sigma - \xi$ - to check later. In particular, we assume that any $x, \hat{x} \in B_{s+\sigma-\xi}^E$ satisfy $|x - \hat{x}|_{s+\sigma-\xi} \leq 2\eta$. Writing

$$(x - \hat{x}) = \phi'^{-1}(x) \cdot \phi(x)(x - \hat{x}),$$

and using

$$\phi'(x)(x - \hat{x}) = \phi(\hat{x}) - \phi(x) - Q(x, \hat{x}),$$

we get

$$x - \hat{x} = \phi'^{-1}(x)(\phi(\hat{x}) - \phi(x) - Q(x, \hat{x})).$$

Taking norms we have

$$\begin{aligned} |x - \hat{x}|_s &\leq \frac{C'}{\sigma^{\tau'}} |y - \hat{y}|_{x, s+\sigma} + \frac{C}{2\xi\tau} |x - \hat{x}|_{s+2\xi+|x-\hat{x}|_{s+\xi}}^2, \\ &\leq \frac{C'}{\sigma^{\tau'}} |y - \hat{y}|_{x, s+\sigma} + \frac{C}{2\xi\tau} |x - \hat{x}|_{s+2\xi+2\eta}^2, \end{aligned}$$

by lemma 1.4.1 and the fact that $|x - \hat{x}|_{s+\xi} \leq |x - \hat{x}|_{s+\sigma-\xi}$ (choosing ξ so that $2\xi < \sigma$ too).

Let us define $\tilde{\sigma} = (2\xi + 2\eta)(1 + 1/s)$ and use the interpolation inequality

$$|x - \hat{x}|_{s+2\eta+2\xi}^2 \leq |x - \hat{x}|_s |x - \hat{x}|_{s+\tilde{\sigma}}$$

to obtain

$$(1 - \frac{C}{2\xi\tau} |x - \hat{x}|_{s+\tilde{\sigma}}) |x - \hat{x}|_s \leq \frac{C'}{\sigma^{\tau'}} |y - \hat{y}|_{x, s+\sigma}.$$

We now choose η so small to have

- $\tilde{\sigma} \leq \sigma - \xi$, which implies $|x - \hat{x}|_{s+\tilde{\sigma}} \leq 2\eta$. It suffices to have $\eta \leq \frac{\sigma}{2(1+\frac{1}{s})} - \frac{3}{2}\xi$.
- $\eta \leq \frac{\xi\tau}{2C}$ in order to have $\frac{C}{2\xi\tau} |x - \hat{x}|_{s+\sigma} \leq \frac{1}{2}$.

A possible choice is $\xi = \frac{\sigma^2}{12}$ and $\eta = \left(\frac{\sigma}{12}\right)^{2\tau} \frac{1}{4C}$, hence our choice of ε . □

PROPOSITION 1.4.2 (Smooth differentiation of ψ). *Let $\sigma < s < s + \sigma$ and ε as in proposition 1.4.1. There exists a constant K such that for every $y, \hat{y} \in B_{s+\sigma}^F(\varepsilon)$ we have*

$$\left| \psi(\hat{y}) - \psi(y) - \phi'^{-1}(\psi(y))(\hat{y} - y) \right|_s \leq K(\sigma) |\hat{y} - y|_{x, s+\sigma}^2,$$

and the map $\psi' : B_{s+\sigma}^F(\varepsilon) \rightarrow L(F_{s+\sigma}, E_s)$ defined locally by $\psi'(y) = \phi'^{-1}(\psi(y))$ is continuous. In particular ψ has the same degree of smoothness of ϕ .

PROOF. Let's baptize some terms

- $\Delta := \psi(\hat{y}) - \psi(y) - \phi'^{-1}(x)(\hat{y} - y)$
- $\delta := \hat{y} - y$, the increment

- $\xi := \psi(y + \delta) - \psi(y)$
- $\Xi := \phi(x + \xi) - \phi(x)$.

With these new notations we can see Δ as

$$\begin{aligned}
\Delta &= \xi - \phi'^{-1}(x) \cdot \Xi \\
&= \phi'^{-1}(x)(\phi'(x) \cdot \xi - \Xi) \\
&= \phi'^{-1}(x)(\phi'(x)\xi - \phi(x + \xi) + \phi(x)) \\
&= -\phi'^{-1}(x)Q(x, x + \xi)
\end{aligned}$$

Taking norms we have

$$|\Delta|_s \leq K|\hat{y} - y|_{x, s+\bar{\sigma}}^2$$

by proposition 1.4.1 and lemma 1.31, for some $\bar{\sigma}$ which goes to zero when σ does, and some constant $K > 0$ depending on σ . Up to substituting σ for $\bar{\sigma}$, we have proved the statement.

In addition

$$\psi'(y) = \phi^{-1}(y)' = \phi'^{-1} \circ \phi^{-1}(y) = \phi'^{-1}(\psi(y)),$$

the inversion of linear operators between Banach spaces being analytic, the map $y \mapsto \phi'^{-1}(\psi(y))$ is continuous. \square

The proof of theorem 1.3 hence follows from theorem 1.4 and the last regularity results.

1.5. Proof of Moser's theorem

Moser's theorem now follows directly from theorem (1.3). In particular

- Let $v \in \mathcal{V} = \bigcup_s \mathcal{V}_s$ close to $u^0 \in \mathcal{U} = \bigcup_s \mathcal{V}_s \cap \mathcal{U}(\alpha, A)$, with say $|u^0 - v|_{s+\sigma} < \varepsilon$
- let $E_s = \mathcal{G}_s \times \mathcal{U}_s(\alpha, A) \times \Lambda$, $E = (E_s)_{s>0}$ and the origin $x_0 = (\text{id}, u^0, 0)$,
- let $B_s(\sigma)(x_0)$ be the ball centered at x_0 of radius σ in the s -norm, then $x = (g, u, \lambda) \in B_s(\sigma)(x_0)$ are such that $g \in \mathcal{G}^\sigma : |g - \text{id}|_s < \sigma$, $u \in \mathcal{U}_s(\alpha, A) : |u - u^0|_s < \sigma$ and $|\lambda| < \sigma$.
- the norms $|g^*v|_s := |v|_{g,s}$ play the role of the previous modified norm $|y|_{x,s}$ on the $F_s = \mathcal{V}_s$.
- $\sigma = 3 \sum_n \sigma_n$ is the total loss of width of analyticity (we start from a $s_0 = s + \sigma$ -neighborhood of the phase space $\mathbb{T}^n \times \mathbb{R}^n$), hence to make the algorithm work we need that the deformation due by g remains below this value, and that at every step the distance between one g_n and the next one g_{n+1} remains sufficiently small: $|g_{n+1} - g_n|_{s_{n+1}} < \sigma_{n+1}$ (this in order for lemma 1.4.1 to apply).
- Actually in proposition 1.3.1 we showed that given δv the choice of $(\delta g, \delta u, \delta \lambda)$ was unique, then ϕ' is locally surjective and injective (hence is both right and left invertible).

- The bounds of ϕ'^{-1} and ϕ'' are the ones in proposition 1.3.1 and lemma 1.3.1.
- The last brick it remains to add is the log-convexity of the weighted norm. Let $x \in E_s$, to prove that $s \mapsto \log |x|_s$ is convex one can easily show that

$$|x|_s \leq |x|_{s_1}^{1-\mu} |x|_{s_0}^\mu, \quad \mu \in [0, 1], \quad \forall s = (1-\mu)s_1 + s_0\mu$$

by Hölder inequality with conjugates $(1-\mu)$ and μ , with the counting measure on \mathbb{Z}^n , observing that $|x|_s$ coincides with the ℓ^1 -norm of the sequence $(|x_k|e^{k|s})$.

Hence the existence of (g, u, λ) such that $g_*u + \lambda = v$ is guaranteed by theorem 1.4, uniqueness and smooth differentiation follow from propositions 1.4.1 and 1.4.2, once $|v - u^0|_{s+\sigma}$ satisfies the required bound.

CHAPTER 2

Normal forms for some class of dissipative systems

The aim of this chapter is to give a first portrait of systems with dissipation in terms of normal forms. Although the spirit remains the same as in the first chapter (i.e. introducing external parameters to compensate degeneracy and linearize the perturbed dynamics), we show that for some particular class of vector fields (arising from real physical problems) one can take advantage of their structure and reduce the number of counter terms needed to solve the conjugacy problem.

We think that this introduction of counter terms - and the issue of their elimination, see chapter 3 - clarifies the difficulties which one must overcome when showing the persistence of quasi-periodic solutions and highlights the role of external free parameters (the so called "drift" or "external frequencies" by some authors in the spin-orbit context) in the issue of finding quasi-periodic attractors.

To set notations we present the Hamiltonian case of Moser's theorem, due to Herman in 1990. We secondly focus on an opportune class of analytic vector fields obtained from the Hamiltonian ones by adding a very particular non hamiltonian linear term in the actions directions. In this special context, we show that we can still consider Hamiltonian transformations, as the presence of the dissipative term does not affect the general Hamiltonian structure of the equations. Eventually, we present a parametrized class of vector fields and prove a "translated torus" theorem in the same spirit as Rüssmann's translated curve theorem [Rüs70]. Two diagrams will summarize the results given.

In what follows we rely on the formalism developed by Féjoz in his remarkable works [Féj12], [Féj10] and [Féj04], in line with the previous chapter.

2.1. Hamiltonian systems: Herman's theorem

The Hamiltonian analogue of Moser's theorem was presented by Michael Herman in a colloquium held in Lyon in 1990. It is also an extension of the normal form theorem of Arnold for vector fields on \mathbb{T}^n . The context is the following. Vector fields will be defined on $\mathbb{T}^n \times \mathbb{R}^n$.

2.1.1. Notations & objects. We adapt previously introduced notations to this context.

As always the standard identification $\mathbb{R}^{n*} \equiv \mathbb{R}^n$ will be used.

2.1.1.1. *Spaces of vector fields.* Let \mathcal{H} be the space of germs of real analytic Hamiltonians defined on some neighborhood of $T_0^n = \mathbb{T}^n \times \{0\} \subset \mathbb{T}^n \times \mathbb{R}^n$, and \mathcal{V}^{Ham} the corresponding set of germs along T_0^n of real analytic Hamiltonian vector fields.

Fixing $\alpha \in D_{\gamma, \tau} \subset \mathbb{R}^n$, consider the affine subspace of \mathcal{H} ,

$$\mathcal{K}^\alpha = \{K \in \mathcal{H} : K(\theta, r) = c + \alpha \cdot r + O(r^2)\}.$$

\mathcal{K}^α is the set of Hamiltonians K for which T_0^n is invariant by the flow u^K and α -quasi-periodic:

$$(2.1) \quad u^K = \begin{cases} \dot{\theta} = \frac{\partial K}{\partial r}(\theta, r) = \alpha + O(r) \\ \dot{r} = -\frac{\partial K}{\partial \theta}(\theta, r) = O(r^2). \end{cases}$$

We define

$$\mathcal{U}^{\text{Ham}}(\alpha, 0) = \{u^K \in \mathcal{V}^{\text{Ham}} : K \in \mathcal{K}^\alpha\}.$$

Introduce the set of counter terms

$$\Lambda^{\text{Ham}} = \{\lambda \in \mathcal{V}^{\text{Ham}} : \lambda(\theta, r) = (\beta, 0)\} = \mathbb{R}^n.$$

We define the complex extension of width s of $\mathbb{T}^n \times \mathbb{R}^n$ as in section 1.2.1, and note \mathcal{H}_s the space of Hamiltonians defined on this extension. \mathcal{K}_s^α is the affine subspace consisting of those $K \in \mathcal{H}_s$ of the form $K(\theta, r) = c + \alpha \cdot r + O(r^2)$.

2.1.1.2. *Spaces of conjugacies.* Let \mathcal{D}_s be the space of maps

$$\varphi = \text{id} + v \in \mathcal{A}(\mathbb{T}_s^n, \mathbb{T}_{\mathbb{C}}^n),$$

fixing the origin.

We consider the contragredient action of \mathcal{D}_s on T_s^n , with values in $T_{\mathbb{C}}^n$:

$$\varphi(\theta, r) = (\varphi(\theta), {}^t\varphi'^{-1}(\theta) \cdot r).$$

This is intended to linearize the dynamics on the tori.

Let \mathcal{B}_s be the space of exact complex valued 1-forms ρ on \mathbb{T}_s^n .

We define $\mathcal{G}_s^{\text{Ham}} = \mathcal{D}_s \times \mathcal{B}_s$ and identify it with the space of exact symplectomorphisms¹

$$\mathcal{G}_s^{\text{Ham}} = \{g \in \mathcal{G}_s : g(\theta, r) = (\varphi(\theta), {}^t\varphi'^{-1}(\theta) \cdot (r + \rho(\theta)))\},$$

¹For "exact symplectomorphism" we mean a symplectic g such that $g^* \lambda - \lambda$ is exact, $\lambda(\theta, r) = \sum_{j=0}^n r_j d\theta_j$ being the fundamental 1-form of Liouville on $\mathbb{T}^n \times \mathbb{R}^n$

The form $\rho = dS$ being exact ($S : \mathbb{T}_s^n \rightarrow \mathbb{C}$), it doesn't change the cohomology class of the torus.²

The corresponding vector fields $\dot{g} \in T_{\text{id}}\mathcal{G}^{\text{Ham}}$ are of the form

$$\dot{g} = (\dot{\varphi}, -r \cdot \dot{\varphi}' + d\dot{S}), \quad \dot{S} \in \mathcal{A}(\mathbb{T}_s^n), \dot{\varphi} \in \mathcal{A}(\mathbb{T}_s^n, \mathbb{C}^n).$$

We have the following

THEOREM 2.1 (Herman). *Let $\alpha \in \mathcal{D}_{\gamma, \tau}$ and $K^0 \in \mathcal{K}^\alpha$. If $H \in \mathcal{H}$ is close enough to K^0 , there exists a unique $(K, g, \beta) \in \mathcal{K}^\alpha \times \mathcal{G}^{\text{Ham}} \times \Lambda^{\text{Ham}}$ close to $(K^0, \text{id}, 0)$ such that*

$$H = K \circ g + \beta \cdot r.$$

Here too, the presence of $\beta \cdot r$ breaks the dynamical conjugacy between H and K : the orbits of $K \in \mathcal{K}^\alpha$ under the action of g , form a subspace of codimension n .

For a proof of this result, known also as "twisted conjugacy theorem", see [Féj10], and [Féj04] for an analogue in the context of Hamiltonians with both tangent and normal frequencies.

Phrased in terms of vector fields, the theorem becomes

THEOREM 2.2 (Herman). *If v^H is close enough to $u^{K^0} \in \mathcal{U}^{\text{Ham}}(\alpha, 0)$, there exists a unique $(g, u^K, \beta) \in \mathcal{G}^{\text{Ham}} \times \mathcal{U}^{\text{Ham}}(\alpha, 0) \times \Lambda^{\text{Ham}}$, close to $(\text{id}, u^{K^0}, 0)$ such that*

$$g_* u^K + \beta \partial_\theta = v^H.$$

REMARK 2.1. *In the Hamiltonian context we can reduce the number of counter terms ($\Lambda^{\text{Ham}} = \mathbb{R}^n$) in the Moser normal form of $v^H = g_* u^H + \lambda$: v^H being Hamiltonian, it would read*

$$v^H(\theta, r) = \left(\frac{\partial H}{\partial r} + \beta, -\frac{\partial H}{\partial \theta} + b + B \cdot r \right);$$

averaging on \mathbb{T}^n the second component, we must have $b = 0 = B$. Indeed, when writing down the cohomological equations, we don't need any b or $B \cdot r$ to control the averages. As a matter of fact, the homological equations corresponding to (1.26)-(1.27)-(1.28) read

$$\begin{aligned} \dot{\varphi}' \cdot \alpha - u_1 \cdot d\dot{S} &= \dot{v}_0^H - \dot{\beta}, \\ d\dot{S}' \cdot \alpha &= \dot{V}_0^H - \dot{\Lambda}_0, \\ -{}^t D\dot{\varphi}' \cdot \alpha + {}^t D(u_1 \cdot d\dot{S}) &= \dot{V}_1^H - \dot{\Lambda}_1, \end{aligned}$$

where $\dot{\lambda}_0 = \varphi'^{-1} \cdot \delta\beta$, $\dot{\Lambda}_0 = -\partial_\theta({}^t \varphi'^{-1} \cdot \rho(\theta)) \cdot \delta\beta$ and $\dot{\Lambda}_1 = {}^t \dot{\lambda}'_0$.

Coherently, the term $\dot{\Lambda}_0$ has 0-average and the $d\dot{S}$ -equation can readily be solved.

²In this work we indicated derivations sometimes by "' ", "d" or "D" to avoid heavy notations.

2.2. Hamiltonian + dissipation: "dissipative Herman" theorem

In Celestial Mechanics dynamical problems taking into account dissipative effects are not very easy to handle. In the last few years, an attempt to study non conservative planetary systems has been to consider problems in which the effect of dissipation is known to be very slight or have some effect only on a very large time scale, which allows us to approximate them with conservative systems to which we add some linear friction term.

2.2.1. Spaces of vector fields. Let $\mathcal{H}_s = \mathcal{A}(\mathbb{T}_s^n)$ and $\mathcal{V}_s^{\text{Ham}}$ the space of Hamiltonian vector fields corresponding to Hamiltonians $H' \in \mathcal{H}_s$. Let now $\eta \in \mathbb{R}$ be a fixed positive constant.

We introduce $(\mathcal{V}^{\text{Ham}} \oplus (-\eta r \partial_r))_s$ and the affine subspace

$$\mathcal{U}_s^{\text{Ham}}(\alpha, -\eta) = \left\{ u \in (\mathcal{V}^{\text{Ham}} \oplus (-\eta r \partial_r))_s : u(\theta, r) = (\alpha + O(r), -\eta r + O(r^2)) \right\},$$

which is nothing but $\mathcal{U}_s^{\text{Ham}}(\alpha, -\eta) = (\mathcal{U}^{\text{Ham}}(\alpha, 0) \oplus (-\eta r \partial_r))_s$.³

We extended the class of Hamiltonian vector fields by adding the very particular linear term $-\eta r$ in the action direction; the class $\mathcal{V}^{\text{Ham}} \oplus (-\eta r \partial_r)$ is mathematically peculiar: it is invariant under the Hamiltonian transformations in \mathcal{G}^{Ham} . Physically, the described system undergoes a constant linear friction which is the same in every directions. For these systems, \mathbb{T}_0^n is an invariant attractive quasi-periodic torus.

2.2.2. Spaces of conjugacies. As well as in the purely Hamiltonian case, we use exact symplectic transformations. If we call \mathcal{D}_s^σ the space real holomorphic invertible maps $\varphi = \text{id} + v : \mathbb{T}_s^n \rightarrow \mathbb{T}_\mathbb{C}^n$, fixing the origin with

$$|v|_s = \max_{1 \leq j \leq n} (|v_j|_s) < \sigma,$$

and \mathcal{B}_s^σ the space of exact 1-forms $\rho(\theta) = dS(\theta)$ on \mathbb{T}_s^n (S being a map $\mathbb{T}_s^n \rightarrow \mathbb{C}$) such that

$$|\rho|_s := \max_{1 \leq j \leq n} (|\rho_j|_s) < \sigma,$$

we consider the space $\mathcal{G}_s^{\text{Ham}, \sigma} = \mathcal{D}_s^\sigma \times \mathcal{B}_s^\sigma$ of those Hamiltonian transformations $g = (\varphi, \rho)$ acting this way

$$g(\theta, r) = (\varphi(\theta), {}^t \varphi'^{-1}(\theta) \cdot (r + \rho(\theta))).$$

The tangent space at the identity of $\mathcal{G}_s^{\text{Ham}}$, $T_{\text{id}} \mathcal{G}_s^{\text{Ham}}$ is endowed with the norm

$$|\dot{g}|_s = \max(|\dot{\varphi}|_s, |\dot{\rho}|_s).$$

According to theorem C.1 and corollary C.1.1, the operators

$$(2.2) \quad \phi : \mathcal{G}_{s+\sigma}^{\text{Ham}, \sigma^2/2n} \times \mathcal{U}_{s+\sigma}^{\text{Ham}}(\alpha, -\eta) \times \mathbb{R}^n \rightarrow \mathcal{V}_s^{\text{Ham}}, \quad (g, u, \beta) \mapsto g_* u + \beta \partial_\theta,$$

³We recall that the notation $r \partial_r$ is a shortcut for $\sum_j^n r_j \partial_{r_j}$.

commuting with inclusions, are well defined.

We have the following

THEOREM 2.3 ("Dissipative Herman"). *If $v \in (\mathcal{V}^{\text{Ham}} \oplus (-\eta r \partial_r))_{s+\sigma}$ is sufficiently close to $u^0 \in \mathcal{U}_{s+\sigma}^{\text{Ham}}(\alpha, -\eta)$, there exists a unique $(g, u, \beta) \in \mathcal{G}_s^{\text{Ham}} \times \mathcal{U}_s^{\text{Ham}}(\alpha, -\eta) \times \mathbb{R}^n$, close to $(\text{id}, u^0, 0)$, such that*

$$g_* u + \beta \partial_\theta = v.$$

The key point relies on the following two technical observations.

LEMMA 2.2.1. *If $g \in \mathcal{G}^{\text{Ham}}$ and $v \in \mathcal{V}^{\text{Ham}} \oplus (-\eta r \partial_r)$, the vector field $g_* v$ is given by*

$$(2.3) \quad \begin{cases} \dot{\Theta} = \frac{\partial \hat{H}}{\partial R} \\ \dot{R} = -\frac{\partial \hat{H}}{\partial \Theta} - \eta R, \end{cases}$$

where

$$\hat{H}(\Theta, R) = H \circ g^{-1}(\Theta, R) - \eta(S \circ \varphi^{-1}(\Theta)).$$

The fact that $\eta \in \mathbb{R}$ is fundamental to maintain the Hamiltonian structure, which would be broken even if η was a diagonal matrix. Geometrically, the action of g on H is "twisted" by the dissipation.

PROOF. $g(\theta, r) = (\Theta, R)$, that is,

$$\begin{cases} \Theta = \varphi(\theta) \\ R = {}^t\varphi'^{-1}(\theta) \cdot (r + dS(\theta)). \end{cases}$$

We have

– in the tangent direction

$$\dot{\Theta} = \varphi'(\theta) \cdot \dot{\theta} = \frac{\partial(H \circ g^{-1})}{\partial R}.$$

– The derivation of \dot{R} requires a little more attention:

$$\begin{aligned} \dot{R} &= \underbrace{({}^t\varphi'^{-1}(\theta))' \cdot r \cdot \dot{\theta}}_A + \underbrace{{}^t\varphi'^{-1}(\theta) \cdot \dot{r}}_B + \underbrace{{}^t\varphi'^{-1}(\theta) \cdot D^2 S(\theta) \cdot \dot{\theta}}_C \\ &\quad + \underbrace{({}^t\varphi'^{-1}(\theta))' \cdot dS(\theta) \cdot \dot{\theta}}_D \end{aligned}$$

where, expanding and composing with g^{-1}

$$\begin{aligned} A &= (-{}^t\varphi'^{-1} \cdot {}^t\varphi'' \cdot {}^t\varphi'^{-1}) \circ \varphi^{-1}(\Theta) \cdot ({}^t\varphi' \circ \varphi^{-1}(\Theta) \cdot R - dS \circ \varphi^{-1}(\Theta)) \cdot \frac{\partial H}{\partial r} \\ B &= -{}^t\varphi'^{-1} \circ \varphi^{-1}(\Theta) \cdot \frac{\partial H}{\partial \theta} - \eta R + \eta {}^t\varphi'^{-1} \circ \varphi^{-1}(\Theta) \cdot dS \circ \varphi^{-1}(\Theta) \\ C &= {}^t\varphi'^{-1}(\theta) \cdot D^2S(\theta) \cdot \frac{\partial H}{\partial r} \\ &= {}^t\varphi'^{-1} \circ \varphi^{-1}(\Theta) \cdot D^2S \circ \varphi^{-1}(\Theta) \cdot \frac{\partial H}{\partial r} \\ D &= -({}^t\varphi'^{-1} \cdot {}^t\varphi'' \cdot {}^t\varphi'^{-1}) \circ \varphi^{-1}(\Theta) \cdot dS \circ \varphi^{-1}(\Theta) \cdot \frac{\partial H}{\partial r} \end{aligned}$$

Remark that if

$$H \circ g^{-1}(\Theta, R) = H(\varphi^{-1}(\Theta), {}^t\varphi' \circ \varphi^{-1}(\Theta) \cdot R - dS \circ \varphi^{-1}(\Theta)),$$

we have

$$\begin{aligned} \frac{\partial H}{\partial \Theta} &= \frac{\partial H}{\partial \theta} \cdot \varphi'^{-1} \circ \varphi^{-1}(\Theta) \\ &+ \frac{\partial H}{\partial r} \cdot [{}^t\varphi'' \circ \varphi^{-1}(\Theta) \cdot \varphi'^{-1} \circ \varphi^{-1}(\Theta) \cdot R - D^2S \circ \varphi^{-1}(\Theta) \cdot \varphi'^{-1} \circ \varphi^{-1}(\Theta)]. \end{aligned}$$

Summing terms we get

$$\dot{R} = -\frac{\partial H \circ g^{-1}}{\partial \Theta} - \eta R + \eta ({}^t\varphi'^{-1} \circ \varphi^{-1}(\Theta) \cdot dS \circ \varphi^{-1}(\Theta)).$$

Introducing the modified Hamiltonian \hat{H} as in the statement, the transformed system has the form $u^{\hat{H}} \oplus (-\eta R \partial_R)$ hence (2.3). \square

The same is true for the pull-back of such a v :

LEMMA 2.2.2. *If $g \in \mathcal{G}^{\text{Ham}}$ and $v \in \mathcal{V}^{\text{Ham}} \oplus (-\eta r \partial_r)$, the vector field $g^*v = g_*^{-1}v$ is given by*

$$(2.4) \quad \begin{cases} \dot{\theta} = \frac{\partial \hat{H}}{\partial r} \\ \dot{r} = -\frac{\partial \hat{H}}{\partial \theta} - \eta r, \end{cases}$$

\hat{H} being $\hat{H}(\theta, r) = H \circ g(\theta, r) + \eta S(\theta)$.

2.2.3. The linearized problem. The main point of the proof of theorem 2.3 is, again, the existence of a right inverse for ϕ' . We hence present the corresponding statement and show that except a minor difference, the system to solve is the same as the one in the purely hamiltonian context.

PROPOSITION 2.2.1. *There exists ε_0 such that if (g, u, β) is in $\mathcal{G}_{s+\sigma}^{\text{Ham}, \varepsilon_0} \times \mathcal{U}_{s+\sigma}^{\text{Ham}}(\alpha, -\eta) \times \mathbb{R}^n$, then for every δv in $(\mathcal{V}^{\text{Ham}} \oplus (-\eta r \partial_r))_{g, s+\sigma}$ there exists a unique triplet $(\delta g, \delta u, \delta \beta) \in T_g \mathcal{G}_s^{\text{Ham}} \times \vec{\mathcal{U}}_s(\alpha, -\eta) \times \mathbb{R}^n$ such that*

$$(2.5) \quad \phi'(g, u, \beta) \cdot (\delta g, \delta u, \delta \beta) = \delta v;$$

moreover, we have the following estimate

$$(2.6) \quad \max(|\delta g|_s, |\delta u|_s, |\delta \beta|) \leq \frac{C}{\sigma^{\tau'}} |\delta v|_{g, s+\sigma},$$

C being a constant that depends only on $|g|_{s+\sigma}$ and $|u|_{s+\sigma}$.

PROOF. The proof is recovered from the one of proposition 1.3.1, additionally imposing that the transformation is Hamiltonian and the vector fields belong to this particular class "Hamiltonian + dissipation". The interesting fact relies on the homological equation intended to "relocate" the torus.

Calculating $\phi'(x) \cdot \delta x$ and pulling back, equation (2.5) reads

$$\begin{aligned} \dot{\varphi}' \cdot \alpha - u_1 \cdot d\dot{S} &= \dot{v}_0^H - \dot{\lambda}_0, \\ d\dot{S}' \cdot \alpha + \eta d\dot{S} &= \dot{V}_0^H - \dot{\Lambda}_0, \\ -{}^t D\dot{\varphi}' \cdot \alpha + {}^t D(Q(\theta)) \cdot d\dot{S} &= \dot{V}_1^H - \dot{\Lambda}_1, \end{aligned}$$

where $\dot{\lambda}_0 = \varphi'^{-1} \cdot \delta \beta$, $\dot{\Lambda}_0 = -\partial_\theta({}^t \varphi'^{-1} \cdot \rho(\theta)) \cdot \delta \beta$ and $\dot{\Lambda}_1 = {}^t \dot{\lambda}'_0$.

Thanks to lemma 2.2.2, the right hand sides consist of Hamiltonian terms, normal directions are of 0-average and, according to the symmetry of a Hamiltonian system, just the first two equations are needed to solve the whole systems, as the third one (corresponding to the coefficient of the linear term of the r -component) turns out to be the transpose of the θ -derivative of the first.

Coherently, the term $\dot{\Lambda}_0$ has 0-average and the $d\dot{S}$ -equation can readily be solved.

Solutions and inequalities follow readily from lemmata 1.2.1-1.2.2 and Cauchy's inequality. \square

REMARK 2.2. *The system above is the one that solves, when $\eta = 0$, the infinitesimal problem of the "twisted conjugacy" theorem presented in [Féj10, §1.1] and sketched in the previous section. Hence, up to the slight difference in the equation determining $d\dot{S}$, the proof of theorem 2.3 follows the same steps and difficulties as in [Féj10] (application of theorem 1.4 in the frame of remark 1.4) and would not bring out anything new, so we omit it.*

2.3. A first portrait

At this point we can give a first diagram that summarizes the results obtained up to now and gives a characterization of the considered dissipative systems in terms of normal forms. Before proceeding, for the sake of completeness we give an immediate corollary to Moser's theorem, about general systems with dissipation.

It turns out that in Astronomy, some problems⁴ admit equations of motions that read like systems in $\mathcal{U}(\alpha, A)$ (remember its definition given in (1.7)). In particular, dissipative effects are supposed to contribute with some linear friction. This translates in the presence of the linear term $A \cdot r$; in these cases A is supposed to have real negative eigenvalues.

In this frame, from the proof of theorem 1.2 and lemma 1.17 in particular, it is immediate to deduce the normal form for dissipative systems like this. If the eigenvalues a_i of A are all distinct and different from 0, then the external parameters are of the form $\lambda = (\beta, B \cdot r)$, with B a diagonal matrix as well. We have the following corollary to Moser's theorem.

COROLLARY 2.3.1. *Let $A \in \text{Mat}_m(\mathbb{R})$ be diagonal with $a_i \neq a_j$ if $i \neq j$. If v is sufficiently close to $u^0 \in \mathcal{U}(\alpha, A)$, there exists a unique $(g, u, \lambda) \in \mathcal{G} \times \mathcal{U}(\alpha, A) \times \Lambda(\beta, B \cdot r)$, close to $(\text{id}, u^0, 0)$, such that*

$$g_* u + \lambda = v,$$

λ being of the form $\lambda = (\beta, \text{diag } B \cdot r)$, B being diagonal.

A first diagram of dissipative systems

Here is the diagram that summarizes our results, from the most general to the purely Hamiltonian one.

$$\begin{array}{ccc}
 \text{Moser:} & \mathcal{G} \times \mathcal{U}(\alpha, A) \times \Lambda(\beta, b + B \cdot r) & \xrightarrow{\simeq \text{loc.}} \mathcal{V} \\
 \\
 \text{General dissip. (diag } A): & \mathcal{G} \times \mathcal{U}(\alpha, A) \times \Lambda(\beta, \text{diag } B \cdot r) & \xrightarrow{\simeq \text{loc.}} \mathcal{V} \\
 & \uparrow & \uparrow \\
 \text{Herman dissip.:} & \mathcal{G}^{\text{Ham}} \times \mathcal{U}^{\text{Ham}}(\alpha, -\eta) \times \Lambda(\beta, 0) & \xrightarrow{\simeq \text{loc.}} \mathcal{V}^{\text{Ham}} \oplus \left(-\eta r \frac{\partial}{\partial r}\right) \\
 \\
 \text{Herman } (\eta = 0): & \mathcal{G}^{\text{Ham}} \times \mathcal{U}^{\text{Ham}}(\alpha, 0) \times \Lambda(\beta, 0) & \xrightarrow{\simeq \text{loc.}} \mathcal{V}^{\text{Ham}}
 \end{array}$$

⁴see [DLCB12] for example

2.4. Normal form "à la Rüssmann"

In the context of the diffeomorphisms of the cylinder $\mathbb{T} \times \mathbb{R}$, Rüssmann proved a result that admits among the most important applications in the study of dynamical systems: the "theorem of the translated curve". We will give an analogue for vector fields of this theorem. But first, we present it in one of its possible forms (see [Yoc92] for this formulation).⁵

Let $A := \mathbb{T}^1 \times \mathbb{R}$ and $g : (\theta, r) \mapsto (\Theta(\theta, r), R(\theta, r))$ a diffeomorphism of A isotopic to the identity, meaning $\Theta(\theta, r) = \theta + \phi(\theta, r)$, with $\phi \in C^\infty(A)$. We say that g is completely integrable if $\phi(\theta, r) = l(r)$ and $R(\theta, r) = r$ are independent of the angles.

Let now $L(\theta, r) = (\theta + l(r), r)$ be a completely integrable diffeomorphism of A , such that $l(0) = \alpha$ and $l'(0) \neq 0$. Fixing $b \in \mathbb{R}$, let T_b be the translation $T_b : (\theta, r) \mapsto (\theta, r + b)$.

THEOREM 2.4 (Rüssmann). *If F is a C^∞ -diffeomorphism of A sufficiently close to L in the C^∞ -topology, there exist $b_F \in (\mathbb{R}, 0)$ and $\psi_F \in C^\infty(\mathbb{T}^1)$, small, such that the graph of ψ_F is an invariant curve of rotation number α of the translated diffeomorphism $T_{b_F} \circ F$.*

Under the action of F , the graph of ψ is globally translated by b , along the second coordinate.

A natural question arises:

Is there a case in which the perturbed vector field is so particular that we can attempt the conjugacy just by adjusting the normal direction by a translation term $b \in \mathbb{R}^n$?

In the next section we show that there is a particular class of vector fields for which we can define a "hybrid normal form"⁶ that both relies on the peculiar structure of the vector fields involved and a torsion property; this makes unnecessary the introduction of *all* the counter terms a priori needed if we would have attacked the problem in the pure spirit of Moser.

2.4.1. A parametrization from Celestial Mechanics. In this section we consider a very particular family of vector fields. They come from Hamiltonians with non-degenerate quadratic term. In order to take advantage of this torsion property (as it is done in Kolmogorov theorem) and handle the effect that a symplectic transformation has on the equations (see lemma 2.4.2), we are led to consider a family of systems parametrized by a translation term in action directions. These vector fields come from the

⁵In the appendix, we prove a more general normal form theorem for diffeomorphism in $\mathbb{T} \times \mathbb{R}$ in analytic class and deduce Rüssmann's one via some additional remarks.

⁶This term has been suggested to me by Bassam Fayad, during one of a series of fruitful discussions in which I told him about this work

so-called "spin-orbit" problem of Celestial Mechanics, presented in the works [CC09] and [SL12]. In this case the system depends on external free parameters $\Omega \in \mathbb{R}^n$.

The starting context is the one of section 2.2 and notations are the same.

We are interested in those $K \in \mathcal{K}^\alpha$ of the form

$$(2.7) \quad K(\theta, r) = c + \alpha \cdot r + \frac{1}{2}Q(\theta) \cdot r^2 + O(r^3),$$

Q being a non degenerate quadratic form on \mathbb{T}_s^n : $\det \frac{1}{(2\pi)^n} \int Q(\theta) d\theta \neq 0$.

There exist s_0 and ε_0 such that $\forall s > s_0$, $K^0 \in \mathcal{H}_s$ and for all $H \in \mathcal{H}_s$ such that $|H - K^0|_{s_0} < \varepsilon_0$ one has

$$\left| \det \int_{\mathbb{T}^n} \frac{\partial^2 H}{\partial r^2}(\theta, 0) \frac{d\theta}{(2\pi)^n} \right| \geq \frac{1}{2} \left| \det \int_{\mathbb{T}^n} \frac{\partial^2 K^0}{\partial r^2}(\theta, 0) \frac{d\theta}{(2\pi)^n} \right| \neq 0.$$

We assume that $s \geq s_0$ and define

$$\mathcal{K}_s^\alpha = \left\{ K \in \mathcal{K}_s^\alpha : |K - K^0|_{s_0} \leq \varepsilon_0 \right\}.$$

We hence consider the corresponding set of vector fields

$$(2.8) \quad \mathcal{U}_s^{\text{Ham}}(\alpha, 0) = \left\{ u^K(\theta, r) = \left(\alpha + \frac{1}{2}Q(\theta) \cdot r + O(r^2), O(r^2) \right) \right\},$$

affine subset of $\mathcal{V}_s^{\text{Ham}} = \{v^{\text{H}} \text{ vector fields along } \mathbb{T}_s^n\}$.

Now, fix $\eta \in \mathbb{R}$ and extend these spaces this way

$$(2.9) \quad \mathcal{U}_s^{\text{Ham}}(\alpha, \eta) := \left(\mathcal{U}_s^{\text{Ham}}(\alpha, 0) \oplus (-\eta r \partial_r) \right)_s \text{ and } \left(\mathcal{V}_s^{\text{Ham}} \oplus (-\eta r + \eta \zeta) \partial_r \right)_s,$$

$\zeta \in \mathbb{R}^n$.

REMARK 2.3. *The considered family*

$$\zeta \mapsto v^{\text{H}} \oplus (-\eta r + \eta \zeta) \partial_r$$

may sound strange at this level. We introduce it in order to fit and treat the equations coming from the astronomical spin-orbit problem (presented in the following) as a direct consequence of the results given in this section.

Like in the previous section, \mathcal{D}_s^σ is the space holomorphic invertible maps $\varphi = \text{id} + v : \mathbb{T}_s^n \rightarrow \mathbb{T}_{\mathbb{C}}^n$, fixing the origin with $|v|_s < \sigma$, while \mathcal{Z}_s^σ the space of closed 1-forms $\rho(\theta) = dS(\theta) + \xi$ on \mathbb{T}_s^n (which we see as maps $\mathbb{T}_s^n \rightarrow \mathbb{C}^n$) such that

$$|\rho|_s := \max(|\xi|, |dS|_s) < \sigma,$$

we consider the set $\mathcal{G}_s^{\omega, \sigma} = \mathcal{D}_s^\sigma \times \mathcal{Z}_s^\sigma$ of those symplectic transformations $g = (\varphi, \rho)$ of the form

$$g(\theta, r) = (\varphi(\theta), {}^t\varphi'^{-1}(\theta) \cdot (r + dS(\theta) + \xi)).$$

The corresponding vector fields $\dot{g} \in T_{\text{id}}\mathcal{G}^\omega$ are of the form

$$\dot{g} = (\dot{\varphi}, -r \cdot \dot{\varphi}' + d\dot{S} + \dot{\xi}), \quad \dot{S} \in \mathcal{A}(\mathbb{T}_s^n), \dot{\xi} \in \mathbb{R}^n, \dot{\varphi} \in \mathcal{A}(\mathbb{T}_s^n, \mathbb{C}^n).$$

Concerning the space of constant counter terms we consider

$$\Lambda(0, b) = \{ \text{constant vector fields: } \lambda = (0, b), b \in \mathbb{R}^n \}.$$

According to the following lemmata and its corollary and corollary C.1.1, the normal form operators (commuting with inclusions)

$$(2.10) \quad \begin{aligned} \phi : \mathcal{G}_{s+\sigma}^{\omega, \sigma^2/2n} \times \mathcal{U}_{s+\sigma}^{\text{Ham}}(\alpha, -\eta) \times \Lambda(0, b) &\rightarrow (\mathcal{V}^{\text{Ham}} \oplus (-\eta r + \eta \mathbb{R}^n) \partial_r)_s, \\ (g, u, \lambda) &\mapsto g_* u + b \end{aligned}$$

are well defined. The following lemmata motivates the choice of the parametrization.

LEMMA 2.4.1. *If $g \in \mathcal{G}^\omega$ and $v \in \mathcal{V}^{\text{Ham}} \oplus (-\eta r \partial_r)$, the push forward $g_* v$ is given by*

$$\begin{cases} \dot{\Theta} = \frac{\partial \hat{H}}{\partial R} \\ \dot{R} = -\frac{\partial \hat{H}}{\partial \Theta} - \eta(R - \xi), \end{cases}$$

where $\hat{H}(\Theta, R) = H \circ g^{-1} - \eta(S \circ \varphi^{-1}(\Theta) + \xi \cdot (\varphi^{-1}(\Theta) - \Theta))$.

The proof is the same as for lemma 2.2.1, taking care of the additional term $\eta^t \varphi'^{-1} \circ \varphi^{-1} \cdot \xi$ coming from the non exactness of $\rho(\theta)$.

Concerning the pull-back intervening in the equation of ϕ'^{-1} , we have the following

LEMMA 2.4.2. *If $g \in \mathcal{G}^\omega$ and $v \in \mathcal{V}^{\text{Ham}} \oplus (-\eta r \partial_r)$, the vector field $g^* v$ is given by*

$$(2.11) \quad \begin{cases} \dot{\theta} = \frac{\partial \hat{H}}{\partial r} \\ \dot{r} = -\frac{\partial \hat{H}}{\partial \theta} - \eta(r + \xi), \end{cases}$$

with $\hat{H}(\theta, r) = H \circ g + \eta S(\theta)$.

PROOF. To be coherent with notations, let us consider

$$v := v^{\text{H}} \oplus (-\eta R \partial_R) = \begin{cases} \dot{\Theta} = \frac{\partial H}{\partial R}(\Theta, R) \\ \dot{R} = -\frac{\partial H}{\partial \Theta}(\Theta, R) - \eta R, \end{cases}$$

which we would like to transform via

$$g^{-1}(\Theta, R) = \begin{cases} \theta = \varphi^{-1}(\Theta) \\ r = {}^t \varphi' \circ \varphi^{-1}(\Theta) \cdot R - dS \circ \varphi^{-1}(\Theta) - \xi. \end{cases}$$

We have

– in the tangent direction

$$\dot{\theta} = \varphi'^{-1} \circ \varphi^{-1}(\Theta) \cdot \dot{\varphi} = \varphi'^{-1}(\theta) \cdot \frac{\partial H}{\partial R} = \frac{\partial(H \circ g)}{\partial r},$$

– in the normal direction

$$\begin{aligned} \dot{r} = & \underbrace{\left(({}^t\varphi'' \cdot \varphi'^{-1}) \circ \varphi^{-1}(\Theta) \right) \cdot \dot{\Theta} \cdot R}_{A} + \underbrace{{}^t\varphi' \circ \varphi^{-1}(\Theta) \cdot \dot{R}}_{B} \\ & \underbrace{-D^2S \circ \varphi^{-1}(\Theta) \cdot \varphi'^{-1} \circ \varphi^{-1}(\Theta) \cdot \dot{\Theta}}_{C}, \end{aligned}$$

where

$$\begin{aligned} A &= {}^t\varphi''(\theta) \cdot \varphi'^{-1}(\theta) \cdot ({}^t\varphi'^{-1}(\theta) \cdot (r + \xi + dS(\theta))) \cdot \frac{\partial H}{\partial R} \\ B &= {}^t\varphi'(\theta) \cdot \left(-\frac{\partial H}{\partial \Theta} - \eta({}^t\varphi'^{-1}(\theta) \cdot (r + \xi + dS(\theta))) \right) \\ &= -\eta(r + \xi) - \eta dS(\theta) - {}^t\varphi'(\theta) \cdot \frac{\partial H}{\partial \Theta} \\ C &= -D^2S(\theta) \cdot \varphi'^{-1}(\theta) \cdot \frac{\partial H}{\partial R}. \end{aligned}$$

As

$$\begin{aligned} \frac{\partial(H \circ g)}{\partial \theta} &= \frac{\partial H}{\partial \Theta} \cdot \varphi'(\theta) \\ &+ \frac{\partial H}{\partial R} \cdot \left[({}^t\varphi'^{-1}(\theta))' \cdot (r + \xi + dS(\theta)) + {}^t\varphi'^{-1}(\theta) \cdot D^2S(\theta) \right], \end{aligned}$$

introducing \hat{H} as in the statement and identifying terms, the lemma follows. \square

Hence, if we consider

$$\mathbb{R}^n \ni \zeta \mapsto v^H \oplus (-\eta r + \eta \zeta) \partial_r,$$

we have

COROLLARY 2.4.1. *The pull back of $v = v^H \oplus (-\eta r + \eta \zeta) \partial_r$ by a symplectic transformation $g \in \mathcal{G}^\omega$ reads*

$$(2.12) \quad g^*v = \begin{cases} \dot{\theta} = \frac{\partial \hat{H}}{\partial r} \\ \dot{r} = -\frac{\partial \hat{H}}{\partial \theta} - \eta(r - \hat{\zeta}), \quad \hat{\zeta} = \zeta - \xi, \end{cases}$$

where $\hat{H}(\theta, r) = H \circ g(\theta, r) + \eta(S(\theta) - \zeta \cdot (\varphi(\theta) - \theta))$.

PROOF. The proof follows readily from lemma (2.4.2) as, the only difference stays in the term "B", giving out an additional term $\eta {}^t\varphi'(\theta) \cdot \zeta$. \square

2.4.2. A translated torus theorem. We are about to prove the following

THEOREM 2.5 (Vector fields "à la Rüssmann"). *If $v = v^H \oplus (-\eta r + \eta\Omega)\partial_r$ is sufficiently close to $\hat{u} = u^{K^0} \oplus (-\eta r + \eta\Omega)\partial_r$, for any $\eta \in [-\eta_0, \eta_0]$, $\eta_0 \in \mathbb{R}^+$, there exists a unique $(g, u, b) \in \mathcal{G}^\omega \times \mathcal{U}^{\text{Ham}}(\alpha, -\eta) \times \Lambda(0, b)$, close to $(\text{id}, u^0, 0)$, such that*

$$g_*u + b\partial_r = v.$$

From the normal form, the image $g(\mathbb{T}_0^n)$ is not invariant by v , but translated in the action direction during each infinitesimal time interval.

The proof can still be recovered from the inverse function theorem 1.4 (in the frame of remark 1.4) and propositions 1.4.1-1.4.2, once we check the invertibility of the corresponding ϕ' with a bound on it and ϕ'' .

PROOF. The main part consists in checking the invertibility of ϕ' . Let

$$\begin{aligned} \phi : \mathcal{G}_{s+\sigma}^{\omega, \sigma^2/2n} \times \mathcal{U}_{s+\sigma}^{\text{Ham}}(\alpha, -\eta) \times \Lambda(0, b) &\rightarrow (\mathcal{V}^{\text{Ham}} \oplus (-\eta r + \eta\mathbb{R}^n))_s, \\ (g, u, b) &\mapsto g_*u + b = v \end{aligned}$$

and the corresponding

$$\phi'(g, u, b) : (\delta g, \delta u, \delta b) \mapsto [g_*u, \delta g \circ g^{-1}] + g_*\delta u + \delta b$$

defined on the tangent space be given. As in proposition 1.3.1, we pull it back and expand vector fields along \mathbb{T}_0^n .

In this context

$$\dot{g} = g'^{-1} \cdot \delta g = (\dot{\varphi}, -{}^t\dot{\varphi}' \cdot r + d\dot{S} + \dot{\xi}),$$

with $\dot{S} : \mathbb{T}_s^n \rightarrow \mathbb{C}$, $\dot{\varphi} \in \mathcal{A}(\mathbb{T}_s^n, \mathbb{C}^n)$, $\dot{\xi} \in \mathbb{R}^n$.

$$(2.13) \quad \dot{\varphi}' \cdot \alpha - Q(\theta) \cdot (d\dot{S} + \dot{\xi}) = \dot{v}_0^H,$$

$$(2.14) \quad d\dot{S}' \cdot \alpha + \eta(d\dot{S} + \dot{\xi}) = \dot{V}_0^H + \eta\widehat{\delta\zeta} - \dot{b},$$

$$(2.15) \quad -{}^tD\dot{\varphi}' \cdot \alpha + {}^tD(Q(\theta)) \cdot (d\dot{S} + \dot{\xi}) = \dot{V}_1^H,$$

where \dot{b} is of the form ${}^t\varphi' \cdot \delta b = (\text{id} + {}^t v') \cdot \delta b$ (remember that $\varphi = \text{id} + v$). As always we wrote "H" to emphasize the Hamiltonian nature of terms.

We are now going to repeatedly apply lemmata 1.2.1, 1.2.2 and Cauchy's estimates. Furthermore, we do not keep track of constants - just know that they may depend on $|x|_{s+\sigma}$ - and hence refer to them as C .

- Note that, averaging the second equation on the torus, we can determine

$$\delta b = \eta(\widehat{\delta\zeta} - \dot{\xi}),$$

hence solve the average free

$$d\dot{S}' \cdot \alpha + \eta d\dot{S} = \dot{V}_0^H - {}^t v' \cdot \delta b.$$

Denoting $\dot{V}_0 = \dot{V}_0^H - \eta^t v' \cdot \widehat{\delta\zeta}$, the solution can be written as

$$(2.16) \quad d\dot{S}(\theta) = \sum_k \frac{\dot{V}_{0,k}}{i k \cdot \alpha + \eta} e^{i k \theta} + \eta M(\theta) \cdot \dot{\xi},$$

where $M(\theta)$ is the matrix whose (ij) component reads $(\sum_k \frac{v_{j,k}^i}{i k \cdot \alpha + \eta} e^{i k \cdot \theta})$. In particular by $|i k \cdot \alpha + \eta| \geq |\eta|$, we have $\eta |M|_s \leq n |v|_{s+\sigma} / \sigma$, which will remain small in all the iterates, not modifying the torsion term (see below).

The Fourier coefficients smoothly depend on η .

REMARK 2.4. *The fact that $d\dot{S}$ has zero average implies that*

$$d\dot{S}(\theta) = 0 + \sum_{k \neq 0} \frac{\dot{V}_k}{i k \cdot \alpha + \eta} e^{i k \cdot \theta}.$$

Hence, when passing to norms on the extended phase space, we can bound the divisors uniformly with respect to η , since $|i k \cdot \alpha + \eta| > |i k \cdot \alpha|$; we just need the standard Diophantine condition (1.4). This will imply that the limit distance $|v - u^0|_{s+\sigma} < \varepsilon$ entailed in theorem 1.4, will be defined for every η varying in some interval containing 0 (ε would depend on η though γ of the Diophantine condition, which appears in C' in the bound of ϕ'^{-1}). This remark is fundamental for the results in the last section.

- Call S_0 the first part of (2.16), averaging on the torus equation (2.13), and thanks to the torsion hypotheses, we determine

$$(2.17) \quad \dot{\xi} = - \left(\frac{1}{(2\pi)^n} \int_{\mathbb{T}} Q \cdot (\eta M + \text{id}) d\theta \right)^{-1} \cdot \left(\frac{1}{(2\pi)^n} \int_{\mathbb{T}} \dot{v}_0 + Q \cdot S_0 d\theta \right),$$

and have

$$|\dot{\xi}| \leq \frac{C}{\sigma^{\tau+n}} |\delta v|_{g,s+\sigma},$$

hence

$$(2.18) \quad |d\dot{S}|_s \leq \frac{C}{\gamma \sigma^{\tau+n}} |\delta v|_{g,s+\sigma} \quad \text{and} \quad |\delta b| \leq \frac{C}{\gamma \sigma^{\tau+n}} |\delta v|_{g,s+\sigma}.$$

- There remains to solve equation (2.13); since

$$(2.19) \quad \dot{\varphi} = L_\alpha^{-1} (\dot{v}_0 + Q \cdot (d\dot{S} + \dot{\xi}))$$

we have

$$(2.20) \quad |\dot{\varphi}|_{s-\sigma} \leq \frac{C}{\gamma^2 \sigma^{2\tau+2n}} |\delta v|_{g,s+\sigma}.$$

As $\delta g = g' \cdot \dot{g}$, we have the same sort of estimates for the wanted δg :

$$(2.21) \quad |\delta g|_{s-\sigma} \leq \frac{1}{\sigma} (|g - \text{id}|_{s+\sigma} + 1) \frac{C}{\gamma^2 \sigma^{2\tau+2n}} |\delta v|_{g,s+\sigma}.$$

– Again, $[u, \dot{g}] + \delta u = \dot{v} - \dot{b}$ determines δu explicitly, and we have

$$|\delta u|_{s-\sigma} \leq \frac{C}{\gamma^2 \sigma^{2\tau+2n+1}} |\delta v|_{g, s+\sigma}.$$

Up to defining $\sigma' = \sigma/2$ and $s' = s + \sigma$ we have proved the following lemma for all s', σ' such that $s' < s' + \sigma'$:

LEMMA 2.4.3. *If (g, u, b) are in $\mathcal{G}_{s+\sigma}^{\omega, \sigma^2/2n} \times \mathcal{U}_{s+\sigma}^{\text{Ham}}(\alpha, -\eta) \times \Lambda(0, b)$ then for every δv in $(\mathcal{V}^{\text{Ham}} \oplus (-\eta r + \eta \mathbb{R}^n))_{g, s+\sigma}$, there exists a unique triplet $(\delta g, \delta u, \delta \lambda) \in T_g \overrightarrow{\mathcal{G}}_s^\omega \times \mathcal{U}_s^{\text{Ham}}(\alpha, -\eta) \times \Lambda(0, b)$ such that*

$$(2.22) \quad \phi'(g, u, \lambda) \cdot (\delta g, \delta u, \delta \lambda) = \delta v;$$

moreover, we have the following estimate

$$\max(|\delta g|_s, |\delta u|_s, |\delta b|) \leq \frac{C'}{\sigma^{\tau'}} |\delta v|_{g, s+\sigma},$$

C' being a constant depending on $|g|_{s+\sigma}$ and $|u|_{s+\sigma}$.

Concerning the bound of ϕ'' , the analogue of lemma 1.3.1 follows readily. It just remains to apply theorem 1.4, and complete the proof for the chosen $v \in (\mathcal{V}^{\text{Ham}} \oplus (-\eta r + \eta \mathbb{R}^n) \partial_r)_{s+\sigma} \in \mathcal{V} = \bigcup_{s>0} \mathcal{V}_s$.

In particular note that the distance $|v - \hat{u}|_{s+\sigma}$, is independent of Ω and that constants C' and C'' (appearing in (1.29) and (1.30)) are eventually uniform with respect to Ω over some closed subset of \mathbb{R}^n , the dependence of Ω being smooth all over the steps. The uniform convergence of the algorithm, then guarantees a C^1 -dependence on Ω of the limit solution. \square

2.4.3. Second portrait. We conclude the chapter with a second diagram of inclusions.

$$\begin{array}{ccc} \text{Moser:} & \mathcal{G} \times \mathcal{U}(\alpha, A) \times \Lambda(\beta, b + B \cdot r) & \xrightarrow[\simeq \text{loc.}]{} \mathcal{V} \\ & & \uparrow \\ \text{"à la Rüssmann":} & \mathcal{G}^\omega \times \mathcal{U}^{\text{Ham}}(\alpha, -\eta) \times \Lambda(0, b) & \xrightarrow[\simeq \text{loc.}]{} \mathcal{V}^{\text{Ham}} \oplus (-\eta r + \eta \mathbb{R}^n) \frac{\partial}{\partial r} \end{array}$$

CHAPTER 3

Invariant tori

The introduction of counter terms in the perturbed-side of the conjugacy equation is an extremely powerful tool. Remember Moser's theorem:

Let a vector field $u^0 \in \mathcal{U}(\alpha, A)$ possessing an invariant quasi-periodic torus of characteristic numbers $\alpha_1, \dots, \alpha_n, a_1, \dots, a_n$ be given. If a vector field v is sufficiently close to u^0 , there exists a unique change of coordinates $g, u \in \mathcal{U}(\alpha, A)$ and a constant vector field $\lambda \in \Lambda$ such that

$$g_* u = v - \lambda.$$

(See section 1.2 to recall definitions of these objects.)

On the one side, thanks to the introduction of λ , the vector field u^0 is not supposed to satisfy any torsion property, on the other one this normal form can be used to deduce the existence of invariant tori, whenever the system disposes of a sufficient number of free parameters - internal or external to it. In fact, the equation we solved, locally, entails that in the space of analytic vector fields \mathcal{V} , the ones conjugated to vector fields having T_0^n invariant, form a subspace $\mathcal{G}_* \mathcal{U}(\alpha, A)$ of finite codimension transversal to Λ (remember that $\dim \Lambda \leq n + n + n^2$), hence if the system depends on a sufficient number of free parameters and λ smoothly depends on them, we can try to tune the parameters so that $\lambda = 0$. The key point in a more concrete situation lays on understanding which free parameters we actually have at our disposal and how we can use them to eliminate the obstructions. The issue of proving the persistence of an invariant torus is reduced to a problem of *finite dimension*. As a meaningful example, in the context of Kolmogorov's theorem the actions themselves actually play the role of free parameters and one can deduce Kolmogorov from Herman's "twisted conjugacy" result (theorem 2.1), by "killing" the β . For a proof of this result and a generalization to lower dimensional tori, see again [Féj10] and the illuminating article of Sevryuk about the "lack-of-parameters" problem [Sev99].

The aim of this chapter is to show how to deduce the existence of an invariant attractive torus in the spin-orbit problem, through this technique of "elimination of parameters". The idea will be to exploit in that context the following reasoning. Notations are the ones given in sections 1.2.3 and

1.3.

Suppose that the vector field $v \in \mathcal{V}$ smoothly depends on some external parameter $\Omega \in B^N(0)$ (the unit ball in \mathbb{R}^N) and that, $u^0 \in \mathcal{U}(\alpha, A)$ being given, v is sufficiently close to it. Suppose also that estimates proven in propositions 1.3.1 and lemma 1.3.1 are uniform with respect to Ω . The parametrized version of Moser's theorem follows readily. Calling ϕ_Ω and ψ_Ω the corresponding parametrizations of the normal form operators, let

$$\psi_\Omega : v \mapsto (g, u, \lambda)$$

be the triplet given by the theorem; if $\Omega \mapsto \lambda(\Omega)$ is submersive, there exists $\bar{\Omega}$ such that $\lambda(\bar{\Omega}) = 0$. In particular, if N equals the dimension of Λ , this point is locally unique. The corresponding g hence conjugates v and u .

The normal form, thus reduces the issue of proving the existence of an invariant torus to the applicability of the standard inverse function theorem in finite dimension.

3.1. First application: Spin-orbit in n d.o.f.

In this section we show how the main result of Stefanelli and Locatelli [SL12, theorem 3.1] can be proved by applying theorem 2.5 "à la Rüssmann" - which provides the existence of a translated torus - and eliminating the translation function.

3.1.1. Normal form & elimination of b . We consider a vector field on $\mathbb{T}^n \times \mathbb{R}^n$ of the form

$$\hat{v} = v^H \oplus (-\eta(r - \Omega)\partial_r)$$

where v^H is a Hamiltonian vector-field whose Hamiltonian H is close to the Hamiltonian in Kolmogorov normal form with non degenerate quadratic part introduced in section 2.4.1:

$$K^0(\theta, r) = \alpha \cdot r + \frac{1}{2}Q(\theta) \cdot r^2 + O(r^3).$$

The vector field \hat{v} is hence close to the corresponding unperturbed \hat{u} :

$$\hat{u} = u^{K^0} \oplus (-\eta(r - \Omega)\partial_r).$$

$\Omega \in \mathbb{R}^n$ is a vector of free parameters representing some "external frequencies" (we will see in the concrete example of the "spin-orbit problem" the physical meaning of Ω). We will note v and u^0 the part of \hat{v} and \hat{u} with $\Omega = 0$.

The following theorem holds

THEOREM 3.1 (Dynamical conjugacy). *Let $v = v^H \oplus (-\eta r \partial_r)$ with v^H sufficiently close to u^{K^0} . There exists a unique $\Omega \in \mathbb{R}^n$ close to 0, a unique*

$u \in \mathcal{U}^{\text{Ham}}(\alpha, -\eta)$ and a unique $g \in \mathcal{G}^\omega$ such that $\hat{v} = v + \eta\Omega\partial_r$ (close to $\hat{u} = u^0 + \eta\Omega\partial_r$) is conjugated to u by g : $\hat{v} = g_*u$.

PROOF. Let us write the non perturbed \hat{u} :

$$(3.1) \quad \hat{u} = \begin{cases} \dot{\theta} = \alpha + O(r) \\ \dot{r} = -\eta r + \eta\Omega + O(r^2). \end{cases}$$

We remark that $\eta\Omega$ is the first term in the Taylor expansion of the counter term $b\partial_r$ appearing in the normal form of theorem 2.5, applied to \hat{v} close to \hat{u} . In particular $\hat{u} = \text{id}_* u^0 + \eta\Omega\partial_r$ by uniqueness of the normal form and, if $\Omega = 0$, \mathbb{T}_0^n is invariant for (3.1).

Hence consider the family of maps

$$\begin{aligned} \psi : (\mathcal{V}^{\text{Ham}} \oplus (-\eta(r - \Omega)\partial_r, \hat{u})) &\rightarrow (\mathcal{G}^\omega \times \mathcal{U}(\alpha, -\eta) \times \Lambda(0, b), (\text{id}, u^0, \eta\Omega)) \\ \hat{v} &\mapsto \psi(\hat{v}) := \phi^{-1}(\hat{v}) = (g, u, b) \end{aligned}$$

associating to \hat{v} the unique triplet provided by the translated torus theorem 2.5.

In order to prove that the equation $b = 0$ implicitly defines Ω , it suffices to show that $\Omega \mapsto b(\Omega)$ is a local diffeomorphism; since this is an open property with respect to the C^1 -topology, and \hat{v} is close to \hat{u} , it suffices to show it for \hat{u} , which is immediate. Remember in particular that $b = \sum_k \delta b_k$ where δb_k , uniquely determined at each step of the Newton scheme, is of the form $\delta b_k = \eta(\widehat{\delta\Omega}_k - \dot{\xi}_k)$. Hence $b = \eta\Omega + (\text{perturbations} \ll \eta\Omega)$.

So there exists a unique value of Ω , close to 0, such that $b(\Omega) = 0$. \square

REMARK 3.1. Ω is the value that compensates the "total translation" of the torus, given by the successive translations provided by the ξ' s at each step of the Newton algorithm; this can be directly seen by looking at the iterates of the Newton operator of theorem 1.4 applied to this problem. Using the same notations, we have $x_0 = (\text{id}, u^0, \eta\Omega)$, $\phi(x_0) = u^0 + \eta\Omega\partial_r$ hence

$$x_1 = x_0 + \phi'^{-1}(x_0) \cdot (v - \phi(x_0)),$$

where $(v - \phi(x_0))$ has no more $\eta\Omega\partial_r$. Thus the term δb_1 determined by $\phi'^{-1}(x_0) \cdot (v - \phi(x_0))$ results in $\delta b_1 = -\eta\delta\xi_1$ (remember system (2.13)-(2.14)-(2.15)). At the second iterate, $\delta b_2 = -\eta\delta\xi_2$, since the term we called $\eta\widehat{\delta\Omega}$ (given by the pull-back of δv_2 by g_1 determined at the previous step) is $\eta\widehat{\delta\Omega} = \eta(\delta\xi_1 - \delta\xi_1) = 0^1$. And so on.

¹Because of the form of g and the fact that $\xi \in \mathbb{R}^n$, the terms $\delta\xi$ and $\dot{\xi}$ appearing in δg and $\dot{g} = g'^{-1} \cdot \delta g$ are the same.

3.2. Spin-Orbit problem of Celestial Mechanics

In this section we present the spin-orbit problem of Celestial Mechanics, studied by Celletti and Chierchia in [CC09] in terms of normal forms. In addition to recover the first result of [CC09, theorem 1] as a consequence of theorems 2.5 and 3.1, that the elimination of the obstructing translation parameter "b" provides here a picture of the space of parameters proper to this physical system (see theorem 3.2). Results in this section will be the starting point of a more global study with respect to (dissipation, frequency, perturbation), developed in the next chapter.

We want to study the rotation of a non rigid triaxial body about its spin axis.

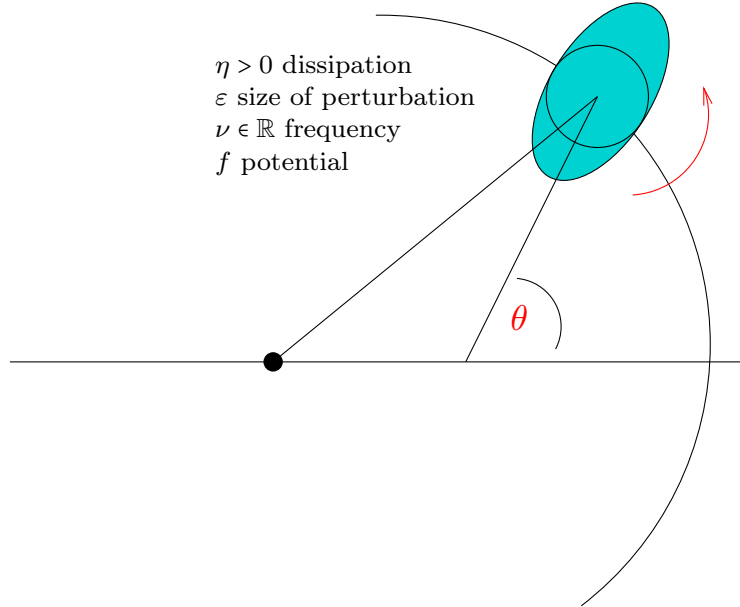

Let us consider a planet orbiting about its star, and make the following assumptions:

- The center of mass of the body moves on a given keplerian orbit focused on a massive point S.
- The body is a triaxial ellipsoid whose spin (polar) axis is considered to be perpendicular to the orbit plane.
- The internal structure of the body is non-rigid. We take small dissipative effects into account: some small internal friction affects the rotation of the body, compromising the conservation of some known quantities (energy, angular momentum...).
- The only dynamical variable we are interested in is the angle θ formed by the direction of the major equatorial axis with the direction of the semi

major axis of the Keplerian ellipse. In other words we just look at the rotation of the satellite around its spin axis.

We say that a satellite is in $n : k$ spin-orbit resonance when it rotates n times around its spin axes while revolving exactly k times about S. There are various examples of such a motion in Astronomy, among which the Moon (1 : 1) or Mercury (3 : 2).

It has been proven (see [GP66]) that a good model of the motion is the equation

$$(3.2) \quad \ddot{\theta} + \eta(\dot{\theta} - \nu) + \varepsilon \partial_{\theta} f(\theta, t) = 0.$$

The conservative part of the equation is obtained by writing $\eta = 0$:

$$\ddot{\theta} + \varepsilon \partial_{\theta} f(\theta, t) = 0.$$

The model follows from the symmetries considered above. Concerning the dissipative terms, an exhaustive physical explanation of how they are introduced in that form can be found in the work of Goldreich and Peale [GP66]. In what we are concerned, we just give - and need - the following indications:

- $(\theta, t) \in \mathbb{T}^2$; in the physical problem the time variable t represents the mean anomaly of the satellite, i.e. the portion of area swept by the orbital radius times 2π
- $\mathbb{R} \ni \eta > 0$ is the fixed "dissipation constant", which may depend on the internal rigidity constant of the body, the eccentricity, Love numbers... There is a real "conflict" about which terms and in which way this constant depends on; of course every body described by this equation has its proper internal structure (number of layers, oceans...) and making a more faithful model is very complicated.
- $\varepsilon > 0$ measures the size of the perturbation, indeed the oblateness of the satellite: when calculating the potential exercised by the satellite, if the two equatorial axes are not of the same length a coupling between r and θ appears and the so called "tidal potential" makes its entrance in addition to the Keplerian one.
- $\nu \in \mathbb{R}$ is a free parameter, representing a frequency proper to the system. We will see its physical meaning in a moment.

We suppose that the potential function is real analytic in all its variables. Now, we can distinguish two particular situations:

- $\varepsilon = 0$ and $\eta \neq 0$:

introducing the vector field associated with (3.2):

$$(3.3) \quad \begin{cases} \dot{\theta} = y \\ \dot{y} = -\eta(y - \nu) \end{cases}$$

and defining $r = y - \nu$, we obtain

$$\begin{cases} \dot{\theta} = \nu \\ \dot{r} = -\eta r. \end{cases}$$

The unique invariant curve is $r = 0$ and its frequency is ν . On the other hand, the general solution of $\ddot{\theta} + \eta(\dot{\theta} - \nu)$ is given by

$$\theta(t) = \nu t + \theta^0 - \frac{y_0 - \nu}{\eta}(1 - e^{-\eta t}),$$

showing that the rotation tends asymptotically to a ν -quasi-periodic behavior. Here the meaning of ν is revealed: ν is the frequency of rotation to which the satellite tends because of the dissipation, if no "oblate-shape effects" are present.

– $\varepsilon \neq 0$ and $\eta = 0$:

we are in the conservative regime, and the KAM theory applies: fixing some α diophantine, if the perturbation is small enough and the associated Hamiltonian has non-degenerate quadratic part, there exists a diffeomorphism conjugating the perturbed system into the α -quasi-periodic unperturbed one.

Let us again observe the unperturbed vector field corresponding to the dissipative equation

$$\begin{cases} \dot{\theta} = y \\ \dot{y} = -\eta(y - \nu) \end{cases}$$

and introduce a Diophantine α by posing $r = y - \alpha$, we obtain

$$(3.4) \quad \begin{cases} \dot{\theta} = \alpha + r \\ \dot{r} = -\eta r + \eta(\nu - \alpha). \end{cases}$$

As we haven't perturbed yet, the term $\eta(\nu - \alpha)$ plays the role of the counter term: we have $b_0 = \eta(\nu - \alpha)$, which we can eliminate only by $\nu = \alpha$. This isn't surprising: with no perturbation, restricting to $r = 0$, there is a quasi-periodic curve of frequency $\dot{\theta} = \nu$.

The main question is: fixing α Diophantine does there exist a value of the proper rotation frequency ν such that the perturbed system possesses an α -quasi-periodic invariant attractive torus?

3.2.1. Extending the phase space. In order to apply our general scheme to the non autonomous perturbation of (3.4), as usual we extend the phase space by introducing the time (or its translates) as a variable. The phase space becomes $\mathbb{T}^2 \times \mathbb{R}^2$ with variable θ_2 corresponding to time and r_2 its conjugated.

Hence consider the family of vector fields (parametrized by $\Omega \in \mathbb{R}$)

$$v = v^H \oplus (-\eta r + \eta \Omega) \partial_r,$$

where $\Omega = (\nu - \alpha, 0)$ and v^H corresponds to

$$(3.5) \quad \begin{aligned} H(\theta, r) &= \alpha \cdot r_1 + r_2 + \frac{1}{2}r_1^2 + \varepsilon f(\theta_1, \theta_2). \\ v &= \begin{cases} \dot{\theta}_1 = \alpha + r_1 \\ \dot{\theta}_2 = 1 \\ \dot{r}_1 = -\eta(r_1 - (\nu - \alpha)) - \varepsilon \frac{\partial f}{\partial \theta_1} \\ \dot{r}_2 = -\eta r_2 - \varepsilon \frac{\partial f}{\partial \theta_2}. \end{cases} \end{aligned}$$

The following objects are essentially the ones introduced in section 2.4, taking into account the introduction of the time-variable $\theta_2 = t$ and its conjugated r_2 .

- let $\bar{\mathcal{H}}$ be space of real analytic Hamiltonians defined in a neighborhood of $T_0 = \mathbb{T}^2 \times \{0\}$ such that for $H \in \bar{\mathcal{H}}$, $\partial_{r_2} H \equiv 1$. For these Hamiltonians the frequency $\dot{\theta}_2 = 1$ (corresponding to time) is fixed.
- Let $\bar{\mathcal{K}} = \bar{\mathcal{H}} \cap \mathcal{K}$ and $\mathcal{K}^{\bar{\alpha}}$ the affine subspace of $\bar{\mathcal{H}}$ defined by

$$\mathcal{K}^{\bar{\alpha}} = \left\{ K \in \bar{\mathcal{K}} : K(\theta, r) = c + \bar{\alpha} \cdot r + \frac{1}{2}Q(\theta) \cdot r^2 + O(r^3), \bar{\alpha} = (\alpha, 1) \right\},$$

$c \in \mathbb{R}$ and $\int_{\mathbb{T}^2} Q_{11}(\theta) d\theta \neq 0$. Hamiltonian vector fields corresponding to some $K \in \mathcal{K}^{\bar{\alpha}}$ are such that $\mathbb{T}^2 \times \{0\}$ is an $\bar{\alpha}$ -quasi-periodic invariant torus.

- \mathcal{V}^{Ham} the space of Hamiltonian vector fields corresponding to H 's in $\bar{\mathcal{H}}$
- $\mathcal{U}^{\text{Ham}}(\bar{\alpha}, 0)$ as its affine subspace consisting of Hamiltonian vector fields corresponding to K 's in $\mathcal{K}^{\bar{\alpha}}$.
- The set $\mathcal{U}^{\text{Ham}}(\bar{\alpha}, -\eta) = \mathcal{U}^{\text{Ham}}(\bar{\alpha}, 0) \oplus (-\eta r) \frac{\partial}{\partial r}$
- The frequencies $\alpha \in \mathbb{R}$ satisfying the following Diophantine condition

$$(3.6) \quad |k_1 \alpha + k_2| \geq \frac{\gamma}{|k|^\tau}, \quad \forall k \in \mathbb{Z}^2 \setminus \{0\}.$$

- The space of real analytic symplectic isomorphisms of $\mathbb{T}^2 \times \mathbb{R}^2$ that leave the time variable unchanged

$$\bar{\mathcal{G}}^\omega = \left\{ g \in \mathcal{G}^\omega : \bar{\xi} = (\xi, 0), \varphi(\theta) = (\varphi_1(\theta), \theta_2) \right\}.$$

It is a well known fact that these transformations keep $H \in \bar{\mathcal{H}}$ in its particular form: the "new action" introduced will not affect the dynamics of the system.

The corresponding $\dot{g} \in T_{\text{id}} \bar{\mathcal{G}}$ are $\dot{g} = (\dot{\varphi}, {}^t \dot{\varphi}' \cdot r + d\dot{S} + \dot{\xi})$ with $\dot{\varphi} = (\dot{\varphi}_1, 0)$ and $\dot{\xi} = (\dot{\xi}_1, 0)$

- $\bar{\Lambda} = \left\{ \lambda : \lambda(\theta, r) = b \frac{\partial}{\partial r_1} \right\} \equiv \mathbb{R}$
- The vector $\Omega \in \mathbb{R}^2$ appearing in the extension is of the form $\Omega = (\nu - \alpha, 0)$.
- As shown in section 1.2.1, we complexify domains and targets and endow spaces with the Fourier's weighted norm.

– By restriction, the normal form operator

$$\begin{aligned} \bar{\phi} : \bar{\mathcal{G}}_{s+\sigma}^{\omega, \sigma^2/2n} \times \mathcal{U}_{s+\sigma}^{\text{Ham}}(\bar{\alpha}, -\eta) \times \bar{\Lambda} &\rightarrow (\mathcal{V}^{\text{Ham}} \oplus (-\eta r + \eta \mathbb{R}) \partial_r)_s, \\ (g, u, \lambda) &\mapsto g_* u + b \partial_{r_1}, \end{aligned}$$

and the corresponding

$$\bar{\phi}'(g, u, \lambda) : T_g \bar{\mathcal{G}}_{s+\sigma}^{\omega, \sigma^2/2n} \times \overrightarrow{\mathcal{U}}_{s+\sigma}^{\text{Ham}}(\bar{\alpha}, -\eta) \times \bar{\Lambda} \rightarrow (\mathcal{V}^{\text{Ham}} \oplus (-\eta r + \eta \mathbb{R}) \partial_r)_{g,s},$$

are now defined.

3.2.2. A curve of invariant tori. We have the following

THEOREM 3.2 (A curve of normally hyperbolic tori). *Fixing α Diophantine and ε sufficiently small, there exists a unique analytic curve C_α , in the plane (η, ν) of the form $\nu = \alpha + O(\varepsilon^2)$, along which the counter term $b(\nu, \alpha, \eta, \varepsilon)$ "à la Rüssmann" vanishes, so that the perturbed system possesses an invariant torus carrying quasi-periodic motion of frequency α . This torus is attractive (resp. repulsive) if $\eta > 0$ (resp. $\eta < 0$).*

The proof can be easily recovered from the previous results. For the sake of completeness we check the main steps.

COROLLARY 3.2.1 (of theorem 2.5, Normal form for time-dependent perturbations). *The operator*

$$\bar{\phi} : \bar{\mathcal{G}}_{s+\sigma}^{\omega, \sigma^2/2n} \times \mathcal{U}_{s+\sigma}^{\text{Ham}}(\bar{\alpha}, -\eta) \times \bar{\Lambda} \rightarrow (\mathcal{V}^{\text{Ham}} \oplus (-\eta r + \eta \mathbb{R} \partial_{r_1}))_s$$

is a local diffeomorphism.

PROOF. The proof is recovered from the one of theorem 2.5; taking into account that the perturbation belongs to the particular class $\bar{\mathcal{H}}$.

LEMMA 3.2.1 (Inversion of $\bar{\phi}'$). *If $(g, u, \lambda) \in \bar{\mathcal{G}}_{s+\sigma}^{\omega, \sigma^2/2n} \times \mathcal{U}_{s+\sigma}^{\text{Ham}}(\bar{\alpha}, -\eta) \times \bar{\Lambda}$, for every $\delta v \in (\mathcal{V}^{\text{Ham}} \oplus (-\eta r + \eta \mathbb{R} \partial_{r_1}))_{g,s+\sigma}$ there exists a unique triplet $(\delta g, \delta u, \delta \lambda) \in T_g \bar{\mathcal{G}}_s^\omega \times \overrightarrow{\mathcal{U}}_s^{\text{Ham}}(\bar{\alpha}, -\eta) \times \Lambda$ such that*

$$\bar{\phi}'(g, u, \lambda)(\delta g, \delta u, \delta \lambda) = \delta v;$$

moreover

$$\max \{ |\delta g|_s, |\delta u|_s, |b| \} \leq \frac{C'}{\sigma^{\tau'}} |\delta v|_{g,s+\sigma},$$

the constant C' depending only on $|g|_{s+\sigma}$ and $|u|_{s+\sigma}$.

PROOF OF THE LEMMA. Following the calculations made in the proof of lemma 2.4.3 we need to solve the following homological equations:

$$(3.7) \quad \bar{\phi}'_1 \cdot \bar{\alpha} - Q_{11}(\theta)(d\dot{S}_1 + \dot{\xi}_1) = \dot{v}_{1,0}^H$$

$$(3.8) \quad d\dot{S}'_1 \cdot \bar{\alpha} + \eta(d\dot{S}_1 + \dot{\xi}_1) = \dot{V}_{1,0}^H + \eta \widehat{\delta \Omega} - (\delta b + \partial_{\theta_1} v^1 \delta b)$$

$$(3.9) \quad d\dot{S}'_2 \cdot \bar{\alpha} + \eta d\dot{S}_2 = \dot{V}_{2,0}^H - \partial_{\theta_2} v^1 \delta b,$$

The lower indices indicate the component and the order of the corresponding term in r whose they are the coefficient.² Hence, the first one corresponds to the direction of θ and the second twos to the zero order term in r in the normal direction.

The tangential equation relative to the time component (that we omitted above) is easily determined: computation gives $\dot{v}_{2,0} = 0$, because of $\delta v \partial_{\theta_2} = 0$ and the form of g'^{-1} , and $\dot{\varphi}_2 = 0$, as well as $Q(\theta) \cdot d\dot{S} \partial_{\theta_2} = 0$.

Equations relative to the linear term, follow from the Hamiltonian character.

– First, determine $\delta b = \eta(\delta\bar{\Omega} - \dot{\xi}_1)$, and solve the average free equations (3.8)-(3.9):

$$d\dot{S}_1 = (L_\alpha + \eta)^{-1}(\dot{V}_{1,0}^H - \partial_{\theta_1} v^1 \delta b), \quad d\dot{S}_2 = (L_\alpha + \eta)^{-1}(\dot{V}_{2,0}^H - \partial_{\theta_2} v^1 \delta b).$$

As before, write $d\dot{S}_1 = S_0(\theta) + \eta M(\theta) \dot{\xi}$.

– Second, the average of equation (3.7) determines

$$\dot{\xi}_1 = -\left(\frac{1}{(2\pi)^2} \int_{\mathbb{T}^2} Q_{11}(\theta) (\text{id} + \eta M(\theta)) d\theta \right)^{-1} \frac{1}{(2\pi)^2} \int_{\mathbb{T}^2} \dot{v}_{1,0}^H + Q_{11}(\theta) S_0(\theta) d\theta,$$

hence we solve it and find

$$\dot{\varphi}_1 = L_\alpha^{-1}(\dot{v}_{0,1}^H + Q_{11}(\theta) \cdot (d\dot{S} + \dot{\xi}_1)).$$

The same kind of estimates as in lemma 2.4.3 hold, hence the required bound. \square

LEMMA 3.2.2. *There exists a constant C'' , depending on $|x|_{s+\sigma}$ such that in a neighborhood of $(\text{id}, u^0, 0) \in \bar{\mathcal{G}}_{s+\sigma}^\omega \times \mathcal{U}_{s+\sigma}^{\text{Ham}}(\bar{\alpha}, -\eta) \times \bar{\Lambda}$ the bilinear map $\phi''(x)$ satisfies the bound*

$$|\phi''(x) \cdot \delta x^{\otimes 2}|_{g,s} \leq \frac{C''}{\sigma^{\tau''}} |\delta x|_{s+\sigma}^2.$$

The proof is straightforward and works as in lemma 1.3.1. \square

PROOF OF THE THEOREM. We observe the following facts:

– the existence of this unique local inverse for ϕ' and the bound of ϕ'' allow to apply theorem 2.5 and prove the result once we guarantee that

$$|v - u^0|_{s+\sigma} = \max\left(\varepsilon \left| \frac{\partial f}{\partial \theta_1} \right|_{s+\sigma}, \varepsilon \left| \frac{\partial f}{\partial \theta_2} \right|_{s+\sigma} \right) \leq \delta \frac{\sigma^{2\tau}}{2^{8\tau} C^2},$$

(here we have replaced the constant η appearing in the abstract function theorem with δ , in order not to generate confusion with the dissipation term). This ensures that the inverse mapping theorem can be applied, as well as the regularity propositions (1.4.1 and 1.4.2). Note that the constant C appearing in the bound contains a factor $1/\gamma^2$ coming from

²We noted with $v^1 = \varphi_1 - \text{id}$, coming from the first component of $\varphi = (\varphi_1, \text{id})$.

the diophantine condition (3.6), independent of η , since the remark 2.4 still holds here.

– For every $\eta \in [-\eta_0, \eta_0]$, apply theorem 3.1 and find the unique ν , such that

$$b(\nu, \eta, \alpha, \varepsilon) = 0,$$

(as in the previous case b is of the form $b = \nu - \alpha + \sum_k \delta\xi$, smooth with respect to ν and η and analytic in ε).

In particular the value of ν that satisfies the equation is of the form

$$\nu(\varepsilon, \eta) = \alpha + O(\varepsilon^2).$$

To see this, just look at the very first step of Newton' scheme

$$x_1 = x_0 + \phi'^{-1}(x_0) \cdot (v - \phi(x_0)),$$

where $x_0 = (\text{id}, u^0, \eta(\nu - \alpha))$. In particular $u^0 = (\alpha, 1, -\eta r_1, -\eta r_2)$, and $(v - \phi(x_0)) = (0, 0, \varepsilon \frac{\partial f}{\partial \theta_1}, \varepsilon \frac{\partial f}{\partial \theta_2})$. Developing the system that gives the first term $\delta x_1 = \phi'^{-1}(x_0) \cdot (v - \phi(x_0))$, due to the particular form of the perturbation and the fact that the torsion is the constant $Q_{11} = 1/2$, the ε -order term $\delta\xi$ is not needed when solving the first equation meant to straighten the tangent dynamics:

$$\begin{aligned} \delta\varphi' \cdot \bar{\alpha} - \frac{1}{2}(d\delta S + \delta\xi_1) &= 0 \\ d\delta S' \cdot \bar{\alpha} + \eta(d\delta S + \delta\xi_1) &= \partial_{\theta_1} f(\theta, 0) - \delta b_1. \end{aligned}$$

As a consequence, $\delta\xi_1 = 0 = \delta b_1$. It remains to remark that the final translation function is given by $b = \eta(\nu - \alpha - \sum_{k \geq 2} \delta\xi_k)$ (see remark 3.1), smoothly depending on η .

□

REMARK 3.2. *The determination of $\nu = \alpha + \sum_{k \geq 2} \delta\xi_k = \alpha + O(\varepsilon^2)$ is consistent with respect to the physics of the problem. If we make a dimensional analysis of the equations after the change of variables provided by the normal form*

$$\begin{cases} \dot{\theta} = \alpha + O(r^2) \\ \dot{r} = -\eta r + b + (r^2), \end{cases}$$

$b = \eta(\nu - \alpha - \sum_{k \geq 2} \delta\xi_k)$, we see that $[\eta] = [\frac{1}{T}]$ as $[r] = [\frac{1}{T}]$ (we introduced r as a frequency, remember equation (3.3)), and ξ as well (it provides the translation of r in the coordinate's change). All this is coherent with $[\dot{r}] = [\frac{1}{T^2}]$; all parameters are physically well defined.³

³To see why $[\eta] = [\frac{1}{T}]$ we refer to [GP66] or [CR13], and references therein for example.

COROLLARY 3.2.2 (Cantor set of surfaces). *Let ε_0 be the maximal value that the perturbation can attain. In the space (ε, η, ν) , to every α Diophantine corresponds a surface $\nu = \nu(\eta, \varepsilon)$ ($\varepsilon \in [0, \varepsilon_0]$) analytic in ε , on which the counter term b vanishes, guaranteeing the existence of invariant attractive (resp. repulsive) tori carrying an $\bar{\alpha}$ -quasi-periodic dynamics.*

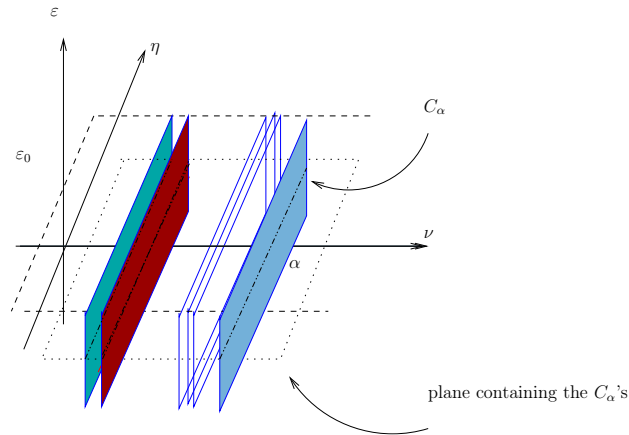

FIGURE 1. The Cantor set of surfaces: transversely cutting with a plane $\varepsilon = \text{const}$ we obtain a Cantor set of curves like the one described in theorem 3.2

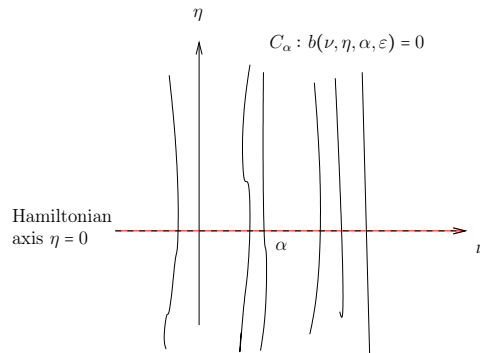

FIGURE 2. The corresponding Cantor set of curves on the plane $\varepsilon = \text{const}$, whose points correspond to an attractive/repulsive invariant torus

3.3. An important dichotomy

The results obtained for the spin-orbit problem, theorem 3.2 and corollary 3.2.2, are intimately related to the very particular nature of the equations of motions. On the one hand it opens the way for a global study of the geometry of the space of parameters (η, ν, ε) , on the other it points out an

existing dichotomy between generic dissipative vector fields and the "modified Hamiltonian" ones considered up to now.

To make it clearer, we recall the cohomological equations in these two contexts and the corresponding spaces of conjugacies.

Equations corresponding to Stefanelli-Locatelli or Celletti-Chierchia read

$$\begin{aligned}\dot{\varphi}' \cdot \alpha - Q(\theta) \cdot (d\dot{S} + \dot{\xi}) &= \dot{v}_0^H, \\ d\dot{S}' \cdot \alpha + \eta(d\dot{S} + \dot{\xi}) &= \dot{V}_0^H + \eta\delta\widehat{\Omega} - \dot{b}, \\ -{}^tD\dot{\varphi}' \cdot \alpha + {}^tD(Q(\theta) \cdot (d\dot{S} + \dot{\xi})) &= \dot{V}_1^H,\end{aligned}$$

the first one corresponding to the constant part with respect to r in the angle direction, the second two to the constant and linear part in the action direction. The objects involved are

- the vector field $u(\theta, r) = (\alpha + O(r), -\eta r + O(r^2))$, obtained from a non degenerate Hamiltonian in Kolmogorov normal form

$$K(\theta, r) = c + \alpha \cdot r + Q(\theta) \cdot r^2 + O(r^3)$$

by adding the linear term $-\eta r \frac{\partial}{\partial r}$.

- the perturbed $v \in \mathcal{V}^{\text{Ham}} \oplus (-\eta(r + \Omega) \frac{\partial}{\partial r})$ along \mathbb{T}_0^n , close to u
- the symplectomorphisms $g(\theta, r) = (\varphi(\theta), {}^t\varphi'^{-1}(\theta) \cdot (r + dS(\theta) + \xi))$ on $\mathbb{T}_{s+\sigma}^n$ and the corresponding tangent vector $\dot{g} = (\dot{\varphi}(\theta), -r\dot{\varphi}'(\theta) + d\dot{S}(\theta) + \dot{\xi})$
- $\dot{v} = g^*\delta v$, $\dot{b} = g^*\delta b$, δv and δb being the variations of v and $b \in \Lambda$ respectively.

Thanks to the Hamiltonian character of both v and u , $g^*\delta v$ conserves its Hamiltonian structure (remember lemma 2.4.1). Only the \mathbb{R}^n -term $\eta\Omega$ undergoes a variation which is added to the modifying part $\eta(r + \Omega)$. Only the first two equations need to be solved.

On the other hand, if the perturbation is not Hamiltonian, equations read

$$\begin{aligned}\dot{\varphi}' \cdot \alpha - Q(\theta) \cdot \dot{R}_0 &= \dot{v}_0, \\ \dot{R}'_0 \cdot \alpha + \eta\dot{R}_0 &= \dot{V}_0 + \eta\delta\dot{\Omega} - \dot{b}, \\ \dot{R}'_1 \cdot \alpha + (Q(\theta) \cdot \dot{R}_0)' &= \dot{V}_1 - \dot{B},\end{aligned}$$

where

- $v \in \mathcal{V}_{s+\sigma}$ has no more underlying Hamiltonian structure
- $g \in \mathcal{G}_s$, is a real analytic isomorphism $g(\theta, r) = (\varphi(\theta), R_0(\theta) + R_1 \cdot r)$.

In this case there is no reason for \dot{V}_0 and \dot{V}_1 to be of zero average, and no relation subsists between the first and the third equation.

First situation. What is so particular about the first situation is the persistence, ε being fixed, of normally hyperbolic quasi-periodic invariant tori for any $\eta \in [-\eta_0, \eta_0]$, $\eta_0 \in \mathbb{R}$. The reason lies in the second cohomological

equation as pointed out in remark 2.4: the given term $\dot{V} = \dot{V}_0^H - \eta(\dot{\xi} + \delta\Omega) - \dot{b}$ being of zero average thanks to the good choice of δb , the formal solution reads

$$d\dot{S}(\theta) = 0 + \sum_{k \neq 0} \frac{\dot{V}_{0,k}}{ik \cdot \alpha + \eta} e^{ik \cdot \theta},$$

and, since $|ik \cdot \alpha + \eta| > |ik \cdot \alpha|$, we can bound the divisors uniformly with respect to η . By the hypothesis of torsion $Q(\theta)$, the only counter-term needed is b , which is eventually eliminated via theorem 3.1.

Second situation. Here, even if the system satisfies some torsion property and one determines the average of \dot{R}_0 at the first equation in order to solve it, there is no way to avoid both the counter term b (used as in the previous case to kill the average and allow a bound uniform on η) and B , in order to solve equation three. Disposing of just n free parameters $\Omega_1, \dots, \Omega_n$, the best possible result is to eliminate b , but it is hopeless to get rid of the obstruction represented by B .

In particular, for the spin-orbit problem in one and a half degree of freedom, using transformations as $g(\theta, r) = (\varphi(\theta), \theta_2, R_0(\theta) + R_1(\theta) \cdot r)$ in $\mathbb{T}^2 \times \mathbb{R}$, the cohomological equations will read

$$\begin{aligned} \dot{\varphi}' \cdot \bar{\alpha} - Q \cdot \dot{R}_0 &= \dot{v}_0, \\ \dot{R}_0' \cdot \bar{\alpha} + \eta \dot{R}_0 &= \dot{V}_0 + \eta \delta \dot{\Omega} - \dot{b}, \\ \dot{R}_1' \cdot \bar{\alpha} + (Q \cdot \dot{R}_0)' &= \dot{V}_1 - \dot{B}, \quad \bar{\alpha} = (\alpha, 1), \delta b, \delta B \in \mathbb{R} \end{aligned}$$

and, disposing of $\nu \in \mathbb{R}$ only, we could try at best to solve $b = 0$.

A **worst situation** could even pop out: if no torsion property is assumed - as in the original form of Moser theorem - we would still have two counter-terms (β to solve the equation tangentially and B to solve the linear term) but the second equation would carry a small divisor η which we cannot allow to get arbitrarily small. A Diophantine condition like $|ik \cdot \alpha + \eta| \geq \gamma / (1 + |k|)^{-\tau}$, for some fixed $\gamma, \tau > 0$, would imply that the bound on ε of theorem 1.4 depends on η through γ :

$$\varepsilon < \gamma^4 C' \leq \eta^4 C',$$

meaning that, once ε is fixed, the curves C_α (obtained by eliminating β for example) do not reach the axis $\eta = 0$ in the plane $\varepsilon = \text{const.}$ (we noted C' all the other terms appearing in the bound).

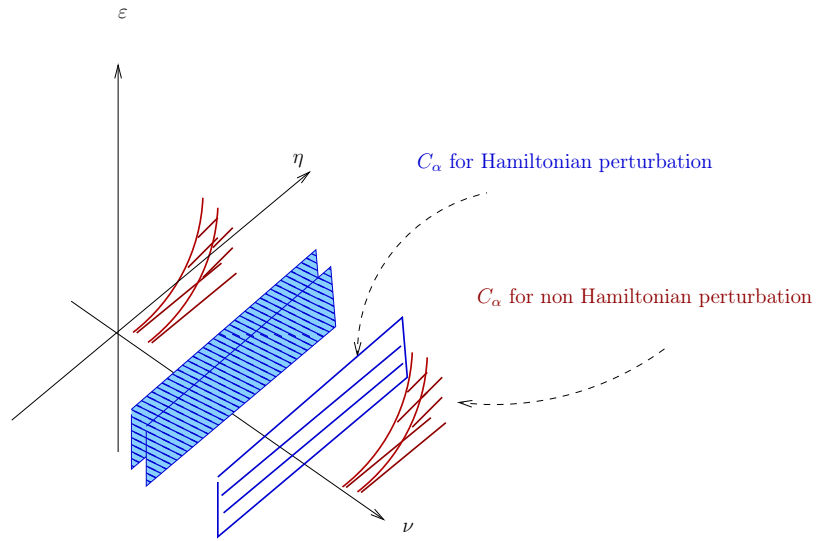

FIGURE 3. The two situations: 1) blue surfaces $\nu = \nu(\eta, \varepsilon)$ corresponding to the case "Hamiltonian + dissipation" of theorem 3.2.2 2) Red surfaces corresponding to the more generic case (no torsion and no Hamiltonian structure): they corresponds to invariant tori of co-dimension 1 ($B \neq 0$).

The parameters' space of the spin-orbit problem: starting a global study

In 1985 A. Chenciner started a study of the dynamical properties of generic 2-parameter families of germs of diffeomorphism of \mathbb{R}^2 which unfold an elliptic fixed point. In [Che85a], he showed that along a certain curve Γ in the space of parameters, we find all the complexity that the dynamics of a germ of generic area preserving diffeomorphism of \mathbb{R}^2 presents, in the neighborhood of an elliptic fixed point. In the same spirit, we take as starting point the results proven in the previous chapter entailing the existence of a Cantor set of curves in the plane dissipation/frequency, corresponding to those values of parameters for which is proved the existence of an invariant attractive (resp. repulsive) torus, for every value of an admissible perturbation.

We recall that the equation corresponding to the spin-orbit problem is

$$\ddot{\theta} + \eta(\dot{\theta} - \nu) + \varepsilon \partial_{\theta} f(\theta, t) = 0,$$

$\eta \in \mathbb{R}^+$ being a fixed constant and f an analytic function 2π -periodic in its arguments, $\nu \in \mathbb{R}$ is the external free frequency aforementioned.

We recall that after the convenient introduction of the frequency α the unperturbed equations relative to the spin-orbit are given by

$$(4.1) \quad \hat{u} = \begin{cases} \dot{\theta} = \alpha + r \\ \dot{r} = -\eta r + \eta(\nu - \alpha), \end{cases}$$

Evidently, when $\nu = \alpha$, $T_0 = \mathbb{T} \times \{r = 0\}$ is an invariant quasi-periodic torus for \hat{u} .

When $\varepsilon \neq 0$, the Cantor set of curves mentioned above consists of $\{C'_\alpha, \alpha \text{ Diophantine}\}$.

At every point of each curve, there exists an invariant attractive/repulsive quasi-periodic torus for the corresponding small perturbation of \hat{u} .

The aim is to understand what happens for values of parameters (η, ν) in the complement of the Cantor set of curves C_α .

Our study starts from the general solution of (4.1)

$$\begin{cases} \theta(t) = \theta(0) + \nu t + [r(0) - (\nu - \alpha)] \frac{1 - e^{-\eta t}}{\eta}, \\ r(t) = r(0) + (e^{-\eta t} - 1)[r(0) - (\nu - \alpha)] \end{cases}.$$

The period of the perturbation being 2π , we are interested in the map

$$(4.2) \quad P(\theta(0), r(0)) = (\theta(2\pi), r(2\pi)).$$

The circle $r = r(0)$ is "translated" by the quantity

$$(4.3) \quad \tau = r(2\pi) - r(0) = (e^{-2\pi\eta} - 1)(r(0) - (\nu - \alpha))$$

and "rotated" by the angle

$$\begin{aligned} \theta(2\pi) - \theta(0) &= 2\pi\nu + [r(0) - (\nu - \alpha)] \frac{1 - e^{-2\pi\eta}}{\eta} \\ &= 2\pi\nu - \frac{\tau}{\eta}. \end{aligned}$$

In particular, the unique circle which is rotated by an angle $2\pi\alpha$ is the one with radius

$$r_\alpha = (\nu - \alpha) \left[1 + \frac{2\pi\eta}{e^{-2\pi\eta} - 1} \right];$$

this circle is translated by the quantity

$$(4.4) \quad \tau_\alpha = 2\pi\eta(\nu - \alpha).$$

At first, we localize our study in a neighborhood of the invariant circle of rotation number $2\pi\nu$ and prove that for high enough values of the dissipation η , this circle persists under the perturbation, no matter what $2\pi\nu$ is. It results a first region where the normal hyperbolicity prevails (see theorem 4.1).

Then, adapting Rüssmann's translated curve theorem to this context, we perform a second localization (section (4.2)), and use all the strength of the Diophantine properties of α to put the perturbation Q in a meaningful normal form. It is then possible to identify a new region in which the normal hyperbolicity is strong enough to imply the existence of an invariant normally hyperbolic circle (section 4.2, theorem 4.2).

In the appendix, we prove an analogue of Moser's theorem for diffeomorphisms of the annulus and deduce Rüssman's result as a consequence. Moreover, applying Rüssmann's translated curve theorem to the perturbed flow, it is still possible to show the existence of curves along which the translation vanishes, this guaranteeing the existence of invariant quasi-periodic circles for generic analytic perturbations Q of P , for values of η sufficiently large with respect to the perturbation.

4.1. Invariant circles of arbitrary rotation number

Corollary 3.2.2 guarantees the existence, in a plane $\varepsilon = \text{const.}$ in the space (η, ν, ε) , of a Cantor set of curves

$$C_\alpha := b(\nu(\eta, \alpha, \varepsilon) = 0$$

along which the invariant attractive torus with Diophantine frequency α persists under perturbation. We recall that all along C_α the perturbed vector field v can be written in the form

$$g_*u = (\alpha + O(\tilde{r}), -\eta\tilde{r} + O(\tilde{r}^2)),$$

where g is a symplectic diffeomorphism, showing that $\eta = 0$ is the only value of transition between the attractive and the repulsive regime of the invariant torus.

4.1.1. The strength of dissipation: graph transform. The map P defined by (4.2) is a global diffeomorphism of $\mathbb{T} \times \mathbb{R}$. After the coordinate change $(\theta, r) \mapsto (\theta, r - (\nu - \alpha) = \rho)$, it reads

$$P(\theta, \rho) = \left(\theta + 2\pi\nu + \frac{1 - e^{-2\pi\eta}}{\eta} \rho, \rho e^{-2\pi\eta} \right)$$

and leaves invariant the circle $\rho = 0$.

Considering

$$Q(\theta, \rho) = \left(\theta + 2\pi\nu + \frac{1 - e^{-2\pi\eta}}{\eta} \rho + \varepsilon f(\theta, r), \rho e^{-2\pi\eta} + \varepsilon g(\theta, r) \right),$$

f and g being two real analytic functions in their arguments, we show that the normal hyperbolicity of the invariant circle implies its persistence under perturbations of size ε , provided it is strong enough with respect to ε .

THEOREM. *If $\eta \gg \sqrt{\varepsilon}$, Q possesses a normally hyperbolic invariant closed curve.*

The proof is decomposed into some lemmata: the key point is to look for the invariant curve as the fixed point of a "graph transform" on an opportune functional space; the dissipation makes the graph transform a contraction.

We start considering the compact $\mathbb{T} \times [-\rho_0, \rho_0]$ centered at $\rho = 0$ in $\mathbb{T} \times \mathbb{R}$ and a Lipschitz map $\varphi : \mathbb{T} \rightarrow [-\rho_0, \rho_0]$, $\theta \mapsto \varphi(\theta)$, with $\text{Lip } \varphi \leq k$. We will call Lip_k the set of Lipschitz functions with Lipschitz constant less than or equal to k .

Let $\text{Gr } \varphi = \{(\theta, \varphi(\theta)) \in \mathbb{T} \times [-\rho_0, \rho_0]\}$ be the graph of φ . For convenience, we have supposed that Q is defined everywhere, hence the composition $Q(\text{Gr } \varphi)$ makes sense.

We note $Q(\theta, r) = (\Theta, R)$. We endow functional spaces with the sup-norm¹ $|\cdot|$, and define, for $z \in \mathbb{T} \times \mathbb{R}$, $|z| := \max(|\pi_1(z)|, |\pi_2(z)|)$, where π_1 and π_2 are the projections on the first and second coordinate.

¹Here we abandon the weighted Fourier's norm

The components of $Q(\theta, \varphi(\theta))$ are:

$$\begin{aligned}\Theta \circ (\text{id}, \varphi)(\theta) &= \theta + 2\pi\nu + \frac{1 - e^{-2\pi\eta}}{\eta} \varphi(\theta) + \varepsilon f(\theta, \varphi(\theta)) \\ R \circ (\text{id}, \varphi)(\theta) &= \varphi(\theta) e^{-2\pi\eta} + \varepsilon g(\theta, \varphi(\theta)).\end{aligned}$$

We define as usual the "graph transform" $\Gamma : \varphi \mapsto \Gamma\varphi$ by:

$$(4.5) \quad \Gamma\varphi : \theta \mapsto R \circ (\text{id}, \varphi) \circ [\Theta \circ (\text{id}, \varphi)]^{-1}(\theta).$$

The graph of $\Gamma\varphi$ is the image by Q of the graph of φ : $Q(\text{Gr } \varphi) = \text{Gr}(\Gamma\varphi)$.

Since $\rho = 0$ is the only invariant curve of P , we hope to find a unique invariant curve of Q as the fixed point of Γ .

The "graph transform" is a standard tool for proving the existence of invariant normally hyperbolic objects (see [Shu78] for instance).

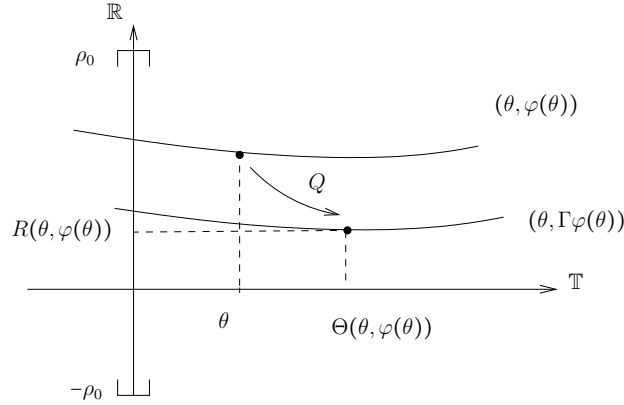

FIGURE 1. How the graph transform acts

We look for a class of Lipschitz functions Lip_k such that Γ defines a contraction of Lip_k in the C^0 metric. Although we are interested in small values of $k > 0$ (ε being small, we do not expect the invariant curve to be in a class of functions with big variations) we will need k as well as η to be larger than ε . We will try to realize this for $1 \gg \eta, k, \varepsilon$, since if η is in the vicinity of 1, the persistence of the invariant circle is very easily shown.

We give some technical lemmata in order to make the proof easier to read.

Since f and g are real analytic on $\mathbb{T} \times [-\rho_0, \rho_0]$, they are Lipschitz.

First of all we have to guarantee the invertibility of $\Theta \circ (\text{id}, \varphi) = \text{id} + u$.

LEMMA 4.1.1. *For every positive η , provided ε is sufficiently small, $\Theta \circ (\text{id}, \varphi)$ is invertible.*

PROOF. If u is a contraction, $\text{id} + u$ is invertible with $\text{Lip}(\text{id} + u)^{-1} \leq \frac{1}{1 - \text{Lip } u}$.

Using the definition of u and f being analytic, we have

$$\begin{aligned} |u(\theta_1) - u(\theta_2)| &\leq \text{Lip } \varphi \frac{(1 - e^{-2\pi\eta})}{\eta} |\theta_1 - \theta_2| + \varepsilon A_f |(\theta_1, \varphi(\theta_1)) - (\theta_2, \varphi(\theta_2))| \\ &\leq (2\pi k + \varepsilon A_f(1 + k)) |\theta_1 - \theta_2|, \end{aligned}$$

with $A_f = \sup(|D_\theta f|, |D_r f|)$. Since $\varepsilon, k \ll 1$, $\text{Lip } u < 1$. \square

LEMMA 4.1.2. *The functions Θ and R are Lipschitz on $\mathbb{T} \times [-\rho_0, \rho_0]$.*

PROOF. It easily follows from the expression of Q . Let z_1 and z_2 in $\mathbb{T} \times [-\rho_0, \rho_0]$, the following inequalities hold:

$$\begin{aligned} |R(z_1) - R(z_2)| &\leq e^{-2\pi\eta} |z_1 - z_2| + \varepsilon A_g |z_1 - z_2| \\ &\leq (e^{-2\pi\eta} + \varepsilon A_g) |z_1 - z_2| \end{aligned}$$

and

$$|\Theta(z_1) - \Theta(z_2)| \leq \left(1 + \frac{(1 - e^{-2\pi\eta})}{\eta} + \varepsilon A_f\right) |z_1 - z_2|,$$

with $A_g = \sup(|D_\theta g|, |D_r g|)$. \square

LEMMA 4.1.3. *The graph transform Γ is well defined from Lip_k to itself, where k satisfies $\varepsilon/\eta < k \ll \eta \ll 1$.*

PROOF. From the definition of the graph transform and the previous lemmata, we have

$$\begin{aligned} |\Gamma\varphi(\theta_1) - \Gamma\varphi(\theta_2)| &\leq \frac{\text{Lip } R \circ (\text{id}, \varphi)}{1 - \text{Lip } u} |\theta_1 - \theta_2| \\ &\leq \frac{ke^{-2\pi\eta} + \varepsilon A_g(1 + k)}{1 - \left[\frac{1 - e^{-2\pi\eta}}{\eta} k + \varepsilon A_f(1 + k)\right]} |\theta_1 - \theta_2|. \end{aligned}$$

We want to find conditions on η and k , such that $\varepsilon \ll 1$ being fixed, Γ is well defined in Lip_k ; we must satisfy

$$ke^{-2\pi\eta} + \varepsilon A_g(1 + k) \leq k \left\{ 1 - \left[\frac{1 - e^{-2\pi\eta}}{\eta} k + \varepsilon A_f(1 + k) \right] \right\},$$

hence

$$k \left\{ 1 - e^{-2\pi\eta} - \left[\frac{1 - e^{-2\pi\eta}}{\eta} k + \varepsilon A_f(1 + k) \right] \right\} \geq \varepsilon A_g(1 + k).$$

It suffices to choose k so that

$$(4.6) \quad 1 \gg \eta \gg k \quad \text{with} \quad k > \frac{\varepsilon}{\eta}.$$

Clearly, the larger η is, the easier it is to realize the inequality. \square

The following technical lemma will be the key of the final proof.

LEMMA 4.1.4. *Let $z = (\theta, \rho)$ be a point in $\mathbb{T} \times [-\rho_0, \rho_0]$ and let η, k, ε satisfy condition (4.6). The following inequality holds for every $\varphi \in \text{Lip}_k$:*

$$|R(\theta, \rho) - \Gamma\varphi \circ \Theta(\theta, \rho)| \leq C|\rho - \varphi(\theta)|,$$

C being a constant smaller than 1.

PROOF. The following chain of inequalities holds:

$$\begin{aligned} |R(\theta, \rho) - \Gamma\varphi \circ \Theta(\theta, \rho)| &\leq |R(\theta, \rho) - R(\theta, \varphi(\theta))| + |R(\theta, \varphi(\theta)) - \Gamma\varphi \circ \Theta(\theta, \rho)| \\ &\leq \text{Lip } R|(\theta, \rho) - (\theta, \varphi(\theta))| + \text{Lip } \Gamma\varphi|\Theta(\theta, \varphi(\theta)) - \Theta(\theta, \rho)|, \end{aligned}$$

from the definition of Γ . We observe that

$$|\Theta(\theta, \varphi(\theta)) - \Theta(\theta, \rho)| \leq \left(\frac{1 - e^{-2\pi\eta}}{\eta} + \varepsilon A_f\right)|\varphi(\theta) - \rho| \leq (2\pi + \varepsilon A_f)|\varphi(\theta) - \rho|,$$

hence

$$|R(\theta, \rho) - \Gamma\varphi \circ \Theta(\theta, \rho)| \leq [\text{Lip } R + \text{Lip } \Gamma\varphi(2\pi + \varepsilon A_f)]|\varphi(\theta) - \rho|,$$

and this chain of inequalities holds

$$\begin{aligned} \text{Lip } R + \text{Lip } \Gamma\varphi(2\pi + \varepsilon A_f) &\leq \text{Lip } R + k(2\pi + \varepsilon A_f) \\ &\leq e^{-2\pi\eta} + \varepsilon A_g + k2\pi + \varepsilon k A_f \\ &= 1 - 2\pi\eta + O(\eta^2) + k2\pi + \varepsilon A_g + \varepsilon k A_f < 1 \end{aligned}$$

since (4.6) holds and, consequently, $\eta \gg \varepsilon, k$ and $\eta \gg k\varepsilon$. \square

We are now ready to state and prove the following

THEOREM 4.1 (Existence of an invariant circle for Q). *If $\eta \gg \sqrt{\varepsilon}$, the map Q possesses a unique invariant circle in the vicinity of $C_0 = \mathbb{T} \times \{\rho = 0\}$.*

PROOF. We want to show that Γ defines a contraction in the space Lip_k : indeed Lip_k is a closed subspace of the Banach space $C^0(\mathbb{T}, [-\rho_0, \rho_0])$, hence complete. The standard fixed point theorem then applies once we show that Γ is a contraction.

Let z be a point of \mathbb{T} , for every φ_1, φ_2 in Lip_k we want to bound

$$|\Gamma\varphi_1(z) - \Gamma\varphi_2(z)|.$$

The trick is to introduce the following point in $\mathbb{T} \times [-\rho_0, \rho_0]$,

$$(\theta, \rho) = ([\Theta \circ (\text{id}, \varphi_1)]^{-1}(z), \varphi_1([\Theta \circ (\text{id}, \varphi_1)]^{-1}(z)))$$

and remark the following equality

$$\begin{aligned} \Gamma\varphi_2 \circ \Theta(\theta, \rho) &= \Gamma\varphi_2(\Theta([\Theta \circ (\text{id}, \varphi_1)]^{-1}(z), \varphi_1([\Theta \circ (\text{id}, \varphi_1)]^{-1}(z)))) \\ &= R \circ (\text{id}, \varphi_2) \circ [\Theta \circ (\text{id}, \varphi_2)]^{-1} \circ [\Theta \circ (\text{id}, \varphi_1)][\Theta \circ (\text{id}, \varphi_1)]^{-1}(z) \\ &= R \circ (\text{id}, \varphi_2) \circ [\Theta \circ (\text{id}, \varphi_2)]^{-1}(z) = \Gamma\varphi_2(z). \end{aligned}$$

We hence apply lemma 4.1.4 to $\varphi = \varphi_1$ at the point (θ, ρ) previously introduced. We have

$$|\Gamma\varphi_1(z) - \Gamma\varphi_2(z)| \leq C |\varphi_1 \circ [\Theta \circ (\text{id}, \varphi_1)]^{-1}(z) - \varphi_2 \circ [\Theta \circ (\text{id}, \varphi_1)]^{-1}(z)|.$$

Taking the supremum for all z and remembering that $C < 1$, concludes the proof of the theorem. \square

4.2. Second localization

In the last section we proved that if η is sufficiently strong, the existence of a unique invariant attractive (resp. repulsive, for negative η) circle is guaranteed. We now consider the part of the (η, ν) -plane defined by $|\eta| \ll 1$, in which the graph transform does not work. In the following we show that it is still possible to find a region where one can put Q into a suitable normal form and deduce, again, the existence of an attracting (resp. repulsive) invariant circle.

In this section, with the help of Rüssmann's theorem we perform a coordinate change $(\theta, \rho) \mapsto (\xi, x)$ on Q , that allow us to see Q as the composition of a diffeomorphism leaving the circle $x = 0$ invariant up to a translation in the r -direction.

In section 4.1.1 we have localized our study to the circle $\rho = 0$; we now want to focus on the translated one with a given rotation $2\pi\alpha$.

To do so, note that the translation function $\tau = 2\pi\eta(\nu - \alpha)$ defines a family of hyperbolas in the (η, ν) -plane.

In the terms of (τ, η) , P becomes

$$(4.7) \quad P(\theta, \rho) = \left(\theta + 2\pi\alpha + \frac{\tau}{\eta} + \frac{1 - e^{-2\pi\eta}}{\eta} \rho, \rho e^{-2\pi\eta} \right);$$

performing the change of variables

$$(\theta, \rho) \mapsto \left(\theta, \rho - \frac{2\pi\eta(\nu - \alpha)}{e^{-2\pi\eta} - 1} = \tilde{\rho} \right),$$

we get

$$P(\theta, \tilde{\rho}) = \left(\theta + 2\pi\alpha + \frac{1 - e^{-2\pi\eta}}{\eta} \tilde{\rho}, \tilde{\rho} e^{-2\pi\eta} + \tau \right).$$

Considering the corresponding perturbed diffeomorphism

$$Q(\theta, \tilde{\rho}) = \left(\theta + 2\pi\alpha + \frac{1 - e^{-2\pi\eta}}{\eta} \tilde{\rho} + \varepsilon f(\theta, \tilde{\rho}), \tilde{\rho} e^{-2\pi\eta} + \tau + \varepsilon g(\theta, \tilde{\rho}) \right),$$

we want to see if there exists an invariant circle even for values of η smaller than the ones given by theorem 4.1.

In the appendix A.2, we deduce Rüssman's theorem in the analytic category, as a consequence of a normal form theorem for diffeomorphisms of the

annulus. This result guarantees, if $2\pi\alpha$ is Diophantine, if P has torsion (in this case $\frac{1-e^{-2\pi\eta}}{\eta} \rightarrow 2\pi$, when $\eta \rightarrow 0$) and if the perturbation is small enough, the existence of an analytic function $\gamma: \mathbb{T} \rightarrow \mathbb{R}$, a diffeomorphism of the torus h close to the identity and $\lambda \in \mathbb{R}$ such that

- the image of the curve $\tilde{\rho} = \gamma(\theta)$ via Q , is the "translated" curve of equation $\tilde{\rho} = \lambda + \gamma(\theta)$
- the restriction of Q to $\text{Gr } \gamma$ is conjugated to the rotation $R_{2\pi\alpha}: \theta \mapsto \theta + 2\pi\alpha$.

As a byproduct, always in the annex, we show that if η is larger than $M\varepsilon$, M a real positive constant, it is still possible to eliminate the translation λ , along some curve of parameters.

Hence, in the conditions of applicability of Rüssmann's theorem, the local diffeomorphism

$$G: (\theta, \tilde{\rho}) \mapsto (h^{-1}(\theta) = \xi, \tilde{\rho} - \gamma(\theta) = x),$$

sends $\tilde{\rho} = \gamma(\theta)$ to $x = 0$ and is such that $G \circ Q \circ G^{-1}$ has $x = 0$ as a translated curve on which the dynamics is the rotation of angle $2\pi\alpha$. We have:

$$\begin{cases} Q(\xi, x) = (\xi', x') \\ \xi' = h^{-1}\left(h(\xi + 2\pi\alpha) + \frac{1-e^{-2\pi\eta}}{\eta}x + \varepsilon \sum_{j=1} \frac{1}{j!} \frac{\partial^j f}{\partial \tilde{\rho}^j}(\theta, \gamma(\theta)) x^j\right), \\ x' = \lambda + xe^{-2\pi\eta} + \gamma(h(\xi + 2\pi\alpha)) - \gamma(h(\xi + 2\pi\alpha) + \frac{1-e^{-2\pi\eta}}{\eta}x + O(|x|)) + \\ + \varepsilon \sum_{i=1} \frac{1}{i!} \frac{\partial^i g}{\partial \tilde{\rho}^i}(\theta, \gamma(\theta)) x^i, \end{cases}$$

hence

$$(4.8) \quad Q(\xi, x) = (\xi + 2\pi\alpha + \sum_i A_i(\xi) x^i, \lambda + \sum_i B_i(\xi) x^i),$$

where

- $B_1(\theta) = e^{-2\pi\eta} - D\gamma(h(\xi + 2\pi\alpha)) \cdot \left(\frac{1-e^{-2\pi\eta}}{\eta} + \varepsilon \frac{\partial f}{\partial \tilde{\rho}}(\theta, \gamma(\theta))\right) + \varepsilon \frac{\partial g}{\partial \tilde{\rho}}(\theta, \gamma(\theta))$, hence it is of order $1 + O(\varepsilon)$,
- $B_i(\theta)$, for $i > 1$, is the coefficient of the order- i term in x from the development of terms as

$$-\frac{1}{i!} D^i \gamma(h(\xi + 2\pi\alpha)) \cdot \left(\frac{1-e^{-2\pi\eta}}{\eta}x + \varepsilon \sum_{j=1} \frac{1}{j!} \frac{\partial^j f}{\partial \tilde{\rho}^j}(\theta, \gamma(\theta)) x^j\right)^i + \varepsilon \frac{1}{i!} \frac{\partial^i g}{\partial \tilde{\rho}^i}(\theta, \gamma(\theta)),$$

and has order $O(\varepsilon)$.

- $A_i(\theta)$ is the order- i term coming from

$$\frac{1}{i!} D^i h^{-1}(h(\xi + 2\pi\alpha)) \cdot \left(\frac{1-e^{-2\pi\eta}}{\eta}x + \varepsilon \sum_{j=1} \frac{1}{j!} \frac{\partial^j f}{\partial \tilde{\rho}^j}(\theta, \gamma(\theta)) x^j\right)^i.$$

In particular $A_i(\theta)$ are of order $1 + O(\varepsilon)$ for $i = 1$ and $O(\varepsilon)$ otherwise.

We noted $\theta = h(\xi)$ and omitted indices indicating the smooth dependence on α, η and τ .

This change of coordinates actually permits us to see Q as the composition of a map

$$\mathcal{I}_{\eta, \tau} = (\xi + 2\pi\alpha + \sum_i A_i(\xi)x^i, \sum_i B_i(\xi)x^i),$$

leaving the circle $x = 0$ invariant, with a translation T_λ in the normal direction. Remark that when $\varepsilon = 0$, we have $h = \text{id}$, $\gamma = 0$ and $\lambda = \tau$, thus Q would read as before the perturbation; in addition even if we don't dispose of the explicit form of the translation function λ , the implicit function theorem tells us that $\lambda = \lambda(\tau) = \tau + O(\varepsilon)$.

We are going to prove:

THEOREM 4.2. *Whenever α is Diophantine, it is possible write Q as the perturbation of a diffeomorphism of the form:*

$$(4.9) \quad N(\Theta, R) = (\Theta + 2\pi\alpha + \sum_{i=1}^k \bar{\alpha}_i R^i, \lambda(\tau, \varepsilon) + \sum_{i=1}^k \bar{\beta}_i R^i),$$

$\bar{\alpha}_i$ and $\bar{\beta}_i$ being constants.

In particular, for values of the parameters belonging to the regions defined by $\eta \gg \varepsilon$ and $|\tau| \leq \eta^2$, Q possesses an invariant attractive quasi-periodic circle.

4.2.1. Towards another normal form. The aim of this section and the following one is to write Q in a form that entails the existence of an invariant circle and to delimit regions in the space of parameters in which the normal hyperbolicity is still strong enough to guarantee its persistence. If $\lambda \neq 0$, it seems impossible to write Q in a form as gentle as $\mathcal{I}_{\eta, \tau}$. The idea is to use all the strength of the translation λ : we perform coordinates changes that push the dependence on the angles as far as possible, let say up to a certain order k , and eventually remark that **all the dependence on the angles of the remaining terms will cancel out with λ** .

Let us try to be more precise.

In the following we do an extensive use of the Diophantine property of α , repeatedly applying lemma A.1.1.

Here we say that α is Diophantine if, for $\gamma, \tau > 0$,

$$(4.10) \quad |k\alpha - l| \geq \frac{\gamma}{|k|^\tau} \quad \forall (k, l) \in \mathbb{N} \setminus \{0\} \times \mathbb{Z}.$$

Using the fact that $B_1(\xi)$ is close to 1, we see that the difference equation

$$(4.11) \quad \log B_1(\xi) + \log X(\xi) - \log X(\xi + 2\pi\alpha) = \frac{1}{2\pi} \int_0^{2\pi} \log B_1(\xi) d\xi$$

then has a unique analytic solution $X(\xi)$ close to 1.

Hence, the coordinates change

$$(4.12) \quad (\xi, x) \mapsto \left(\xi, \frac{x}{X(\xi)} = y\right)$$

transforms Q into a map of the form

$$\begin{cases} Q(\xi, y) = (\xi', y') \\ \xi' = \xi + 2\pi\alpha + \sum_{i=1}^k \alpha_i(\xi) y^i + O(\varepsilon|y|^{k+1}) \\ y' = \lambda + \bar{\beta}_1 y + \sum_{i=2}^k \beta_i(\xi) y^i + O(\varepsilon|y|^{k+1}) + O(\varepsilon|\lambda||y|) + O(\varepsilon|\lambda|), \end{cases}$$

where

$$(4.13) \quad \bar{\beta}_1 = \exp \frac{1}{2\pi} \int_0^{2\pi} \log B_1(\xi) d\xi = 1 - 2\pi\eta + 2\pi^2\eta^2 + \varepsilon M_1 + \varepsilon^2 M_2 + O(\varepsilon\eta) + O(\varepsilon^3, \eta^3),$$

M_i being constants coming from the average of the order- ε^i terms in the Taylor's expansion of $\log B_1(\xi)$.

Just as for (4.11), there is a unique analytic solution $X^{(2)}(\xi)$, smoothly depending on the parameters - through $\bar{\beta}_1$ -, of the equation

$$(4.14) \quad \bar{\beta}_1^2 X^{(2)}(\xi + 2\pi\alpha) - \bar{\beta}_1 X^{(2)}(\xi) + \beta_2(\xi) = \frac{1}{2\pi} \int_0^{2\pi} \beta_2(\xi) d\xi = \bar{\beta}_2.$$

The change of variables

$$(4.15) \quad (\xi, y) \mapsto (\xi, y + X^{(2)}(\xi) y^2)$$

then transforms the non constant coefficient $\beta_2(\xi)$ into its average $\bar{\beta}_2$.

Generalizing, by composing the following changes of variables

$$(4.16) \quad \begin{cases} (\xi, y) \mapsto (\xi, y + X^{(i)}(\xi) y^i) & i = 2, \dots, k \\ \bar{\beta}_1^i X^{(i)}(\xi + 2\pi\alpha) - \bar{\beta}_1 X^{(i)}(\xi) + \beta_i(\xi) = \bar{\beta}_i \end{cases}$$

and

$$(4.17) \quad \begin{cases} (\xi, y) \mapsto (\xi + Z^{(i)}(\xi) y^i, y) & i = 1, \dots, k \\ \bar{\beta}_1^i Z^{(i)}(\xi + 2\pi\alpha) - Z^{(i)}(\xi) + \alpha_i(\xi) = \bar{\alpha}_i \end{cases}$$

we are able to put Q in the form

$$(4.18) \quad \begin{cases} Q(\Theta, R) = (\Theta', R') \\ \Theta' = \Theta + 2\pi\alpha + \sum_{i=1}^k \bar{\alpha}_i R^i + O(\varepsilon|R|^{k+1}) + O(|\lambda|\varepsilon) \\ R' = \lambda + \bar{\beta}_1 R + \sum_{i=2}^k \bar{\beta}_i R^i + O(\varepsilon|R|^{k+1}) + O(|\lambda|\varepsilon), \end{cases}$$

where $\bar{\alpha}_1$ and $\bar{\beta}_1$ are of order $1 + O(\varepsilon)$ while $\bar{\alpha}_i, \bar{\beta}_i$ for $i > 1$, of order $O(\varepsilon)$.

We thus have been able to confine the angle's dependency entirely in the terms $O(\dots)$; in particular the terms $O(|\lambda|\varepsilon)$ vanish when no translation occurs.

4.2.2. Normally hyperbolic invariant circle, again. Starting from (4.18) we show that Q possesses an invariant normally hyperbolic attractive (resp. repulsive) circle, provided that the parameters (η, ν, ε) lie in some delimited regions in the space.

PROPOSITION 4.2.1. *If $\eta \gg \varepsilon$ and $|\tau| \leq \eta^2$, the diffeomorphism Q possesses an invariant attractive (resp. repulsive) circle.*

This proposition is an improvement (with respect to the previous result, valid for all kind of frequency) in terms of the minimal admissible size of η that guarantees a normally hyperbolic regime.

The diffeomorphism Q is a perturbation of the normal form

$$(4.19) \quad N_{\eta, \tau}(\Theta, R) = (\Theta + 2\pi\alpha + \sum_{i=1}^k \bar{\alpha}_i R^i, \lambda(\tau, \varepsilon) + \sum_{i=1}^k \bar{\beta}_i R^i),$$

which possesses an invariant circle $R = R_0$, solution of $R = \lambda + \sum_{k=1} \bar{\beta}_i R^i$.

Using the implicit function theorem and the structure of the terms $\bar{\beta}_1$ and $\bar{\beta}_2$, we have

$$(4.20) \quad R_0 = \frac{-\lambda}{\bar{\beta}_1 - 1} + O\left(\frac{|\lambda|^2 |\bar{\beta}_2|}{|\bar{\beta}_1 - 1|^3}\right) = R_- + O\left(\varepsilon \frac{|R_-|^2}{|\bar{\beta}_1 - 1|}\right),$$

where R_- reads more explicitly as

$$R_- = \frac{-\tau + O(\varepsilon)}{-2\pi\eta + \varepsilon M + O(\varepsilon\eta) + O(\eta^2, \varepsilon^2)}.$$

The goal is now to determine some region in the space of parameters in which it is still possible to apply the graph transform method to prove the existence of a normally hyperbolic invariant circle close to R_0 .

In order to do so, we perform a last change of variables:

$$(\Theta, R) \mapsto (\Theta, R - R_0 = \tilde{R}).$$

Now centered at R_0 , the diffeomorphism Q reads

$$\begin{cases} Q(\Theta, \tilde{R}) = (\Theta', \tilde{R}') \\ \Theta' = \Theta + 2\pi\alpha + \bar{\alpha}_1 R_0 + \sum_{i=1}^k \bar{\alpha}_i \tilde{R}^i + O(\varepsilon |R_0| |\tilde{R}|) + O(\varepsilon |\tilde{R}|^{k+1}) + O(\varepsilon |R_0|^2) + O(\varepsilon |\lambda|) \\ \tilde{R}' = (\bar{\beta}_1 + \sum_{i=2}^k i \bar{\beta}_i R_0^{i-1}) \tilde{R} + O(\varepsilon |R_0| |\tilde{R}|^2) + O(\varepsilon |\tilde{R}|^2) + O(\varepsilon |R_0|^2) + O(\varepsilon |\lambda|). \end{cases}$$

Now $\tilde{R} = 0$ is the invariant circle of the normal form, and the terms $O(\varepsilon |R_0|^2) + O(\varepsilon |\lambda|)$ represent perturbations.

To better see, let us write explicitly the order one term:

$$(4.21) \quad \tilde{R}' = (1 - 2\pi\eta + \varepsilon M_1 + O(\varepsilon\eta) + \sum_{i=2}^k i \bar{\beta}_i R_0^{i-1}) \tilde{R} + O(\dots)$$

In the region defined by

$$(4.22) \quad \begin{cases} \eta \geq \sqrt{2\pi}|\nu - \alpha|, & \text{hence } |\tau| \leq \eta^2 \\ \eta \gg \varepsilon, \end{cases}$$

the term $\bar{\beta}_2 R_0$ is of order $O(\varepsilon\eta) + \frac{O(\varepsilon^2)}{O(\eta)}$.

We remark in particular that each region of this type actually contains the curve C_α along which $\nu = \alpha + O(\varepsilon^2)$.

This point being crucial for the following, it calls for an

Important comment. Up to now, we have made our calculations without making any hypothesis on εf and εg , which led us, following coordinates changes, to the expression in (4.21). In the previous chapter for the spin-orbit problem we proved the existence of a Cantor of curves C_α , for which there exists a normally hyperbolic attractive (resp. repulsive, when $\eta < 0$) invariant torus provided the perturbation is small enough. In particular, the bound on the perturbation was uniform with respect to η , meaning that *to every fixed value* of $\varepsilon_0 < \varepsilon$, in the space (ε, η, ν) the plane $\varepsilon = \varepsilon_0$ contains the C'_α s of normally hyperbolic dynamics and that these curves are defined even for $|\eta|$ small enough, and passing through the $\eta = 0$ change their dynamical regime. By normal hyperbolicity, we know a priori that in a thin cusp neighborhood along each of these curves a normally hyperbolic invariant circle persists (normally hyperbolicity is a stable property).

The regions we defined above enlarge the known domain of normal hyperbolicity which, up to now, we know to include values of $\eta \gg \sqrt{\varepsilon}$. Nevertheless, if we hope to draw these regions till $\eta = 0$, the terms $\varepsilon^i M_i$ constitute an obstruction to the normal hyperbolicity, which would be guaranteed if $(1 - 2\pi\eta)$ dominated over the rest.

In addition, not even the first order term of the time- ε flow ϕ_v^ε of

$$v = \begin{cases} \dot{\theta} = \alpha + r \\ \dot{r} = -\eta r + \eta(\nu - \alpha) - \varepsilon f_\theta(\theta, t) \end{cases},$$

hints anything about the nullity of, at least, the first term εM , once we impose the only exploitable information we have: the corresponding flow is conformally symplectic, as the divergence of v is equal to the constant $-\eta$. Hence $\phi_v^\varepsilon^* d\theta \wedge dr = e^{-\varepsilon\eta} d\theta \wedge dr$.

In addition, let us suppose that Q lives in the class of those flows for which $\varepsilon^i M_i = 0$. Even in this very special case, η won't be allowed to reach 0; the first term would be

$$(4.23) \quad \tilde{R}' = (1 - 2\pi\eta + \frac{O(\varepsilon^2)}{O(\eta)} + O(\varepsilon\eta))\tilde{R} + \dots,$$

and if we want $1 - 2\pi\eta$ to dominate, η still has to satisfy $\eta \gg \varepsilon$. Our regions would then stop at a certain point and cannot follow tightly the C'_α s till the end.

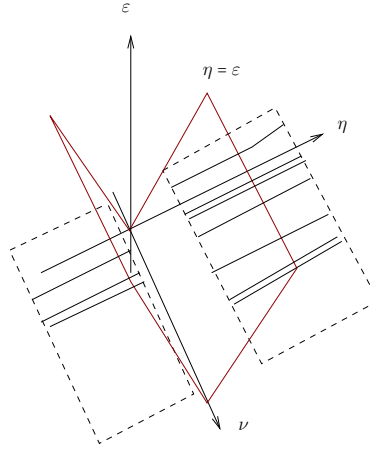

In the region defined by $|\tau| \leq \eta^2$ and $\eta \gg \varepsilon$, R_0 is of order $O(\eta) + O(\varepsilon/\eta)$ and $O(\lambda) = O(\eta^2) + O(\varepsilon)$; our system reads

$$\begin{cases} Q(\Theta, \tilde{R}) = (\Theta', \tilde{R}') \\ \Theta' = \Theta + 2\pi\alpha + \bar{\alpha}_1 R_0 + (C + O(\varepsilon))\tilde{R} + O(\varepsilon|\tilde{R}|^2) + O(\varepsilon|R_0|^2) + O(\varepsilon^2) + O(\varepsilon\eta^2) \\ \tilde{R}' = (1 - 2\pi\eta + O(\varepsilon) + O(\varepsilon\eta))\tilde{R} + O(\varepsilon|\tilde{R}|^2) + O(\varepsilon|R_0|^2) + O(\varepsilon^2) + O(\varepsilon\eta^2), \end{cases}$$

having denoted by C the twist $\frac{1-e^{-2\pi\eta}}{\eta}$. In particular the term $O(\varepsilon|R_0|^2)$ is constant and much smaller than ε , in the region considered.

Applying the "graph transform" method in the annulus $|\tilde{R}| \leq 1$ centered at $\tilde{R} = 0$, is now an easy matter. The preponderance of $1 - 2\pi\eta$ with respect to the reminder's terms in the regions considered, makes the procedure work and guarantee the existence of an attractive (resp. repulsive) circle in a neighborhood of R_0 .

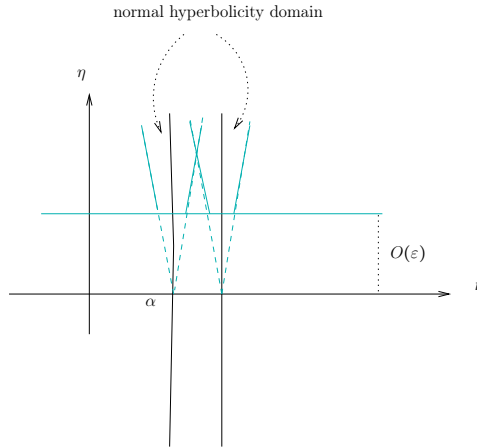

4.3. Summary of the results

We conclude by summing up results presented up to now, which give a first "decoupage" of the parameters' space of the spin-orbit flow in terms of regions in which the existence of an attractive/repelling invariant circle is guaranteed.

Cantor set of curves. We start by recalling that the existence of the Cantor set of curves C_α in the plane (ν, η) for every fixed value of admissible ε is subordinated to the elimination of the translation function of the torus: the parameter b "à la Rüssmann" of theorem 2.5 in the case of vector fields, or of section (A.11) in the case of diffeomorphisms. This elimination, which takes place for any η for vector fields of the spin-orbit, it is not guaranteed for generic diffeomorphisms close to the spin-orbit unperturbed flow as considered in this chapter. Still, in section (A.2.4) of the Appendix, we prove the existence of a Cantor set of curves that exist up to values of η greater than a fixed admissible perturbation ε . Along the curves the existence of an invariant quasi-periodic Diophantine torus is guaranteed and the further study of "what happens between the curves" provided in this chapter apply.

Graph transforms 1&2. In the first section of the current chapter we gave a first rough region in which the existence of an invariant attractive/repelling curve is guaranteed for any rotation $2\pi\alpha$ provided that the normal hyperbolicity (given by the dissipation term $e^{-2\pi\eta r}$) prevails over the perturbative terms : $\eta \gg \sqrt{\varepsilon}$.

In the following, we performed a second localization and used all the Diophantine properties of the rotation number to apply Rüssmann translated curve theorem and changes of coordinates that allowed to write the perturbed diffeomorphism in a meaningful form: we drew regions in which it is still possible to apply the graph transform technique to prove the existence of an invariant attractive/repelling torus: $\eta \gg \varepsilon, |\tau| < \eta^2$.

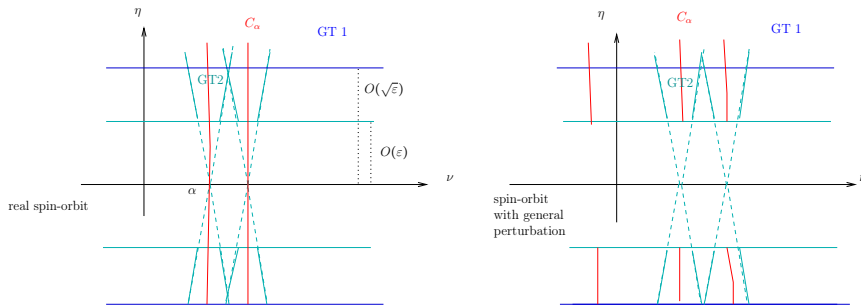

FIGURE 2. Two situations: for the real spin-orbit flow curves reach the Hamiltonian axes, they stop at the order $O(\varepsilon)$ otherwise.

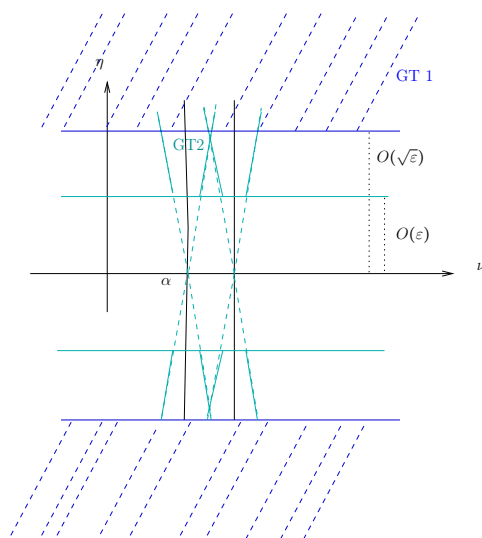

FIGURE 3. Graph transform improvement.

These conic regions contain the curves C_α where $\nu = \alpha + O(\varepsilon^2)$ in the actual spin-orbit time 2π -flow and $\nu = \alpha + O(\varepsilon)$ otherwise. In the case of the actual spin-orbit flow (the one corresponding to equation (3.2)) they reach the $\eta = 0$ axis. By stability of the normal hyperbolicity, we know a priori that in a thin cusp region around every C_α we can guarantee the persistence of invariant attractive/repelling curve. Unfortunately, our knowledge of C_α is not explicit enough to allow a quantitative description of this thin neighborhood. Alternative topological arguments such as Morse index theory or the Wazevsky theorem would still provide answers for values of η up to order ε , thus preventing us to say which region contains the other in the $O(\varepsilon)$ -strip.

For generic perturbations the dynamics contained in this strip is expected to be very rich: in a further study the existence of Birkhoff attractors and Aubry-Mather sets is likely to be proven.

APPENDIX A

A normal form theorem for diffeomorphisms in $\mathbb{T} \times \mathbb{R}$

We are interested in real analytic diffeomorphisms in $\mathbb{T} \times \mathbb{R}$ that, in the neighborhood of the circle $T_0 = \mathbb{T} \times \{r = 0\}$, can be expressed as

$$(A.1) \quad Q(\theta, r) = (\theta + 2\pi\alpha + f(\theta, r), (1 + A) \cdot r + g(\theta, r));$$

where $\alpha \in \mathbb{R}$ satisfies the following Diophantine condition for $\gamma, \tau > 0$

$$(A.2) \quad |k\alpha - l| \geq \frac{\gamma}{|k|^\tau} \quad \forall (k, l) \in \mathbb{N} \setminus \{0\} \times \mathbb{Z},$$

and A is a positive or negative real constant, f, g are real analytic functions. If $A \neq 0$, T_0 is a normally hyperbolic invariant circle of

$$(A.3) \quad P^0(\theta, r) = (\theta + 2\pi\alpha + O(r), (1 + A)r + O(r^2)),$$

of which Q represents a perturbation.

We call $U(\alpha, A)$ the sets of germs along T_0 of real analytic diffeomorphism of the form (A.3).

We introduce the set of germs of real analytic transformations:

$$(A.4) \quad \mathcal{G} = \{G : G(\theta, r) = (\varphi(\theta), R_0(\theta) + R_1 \cdot r)\},$$

φ being a diffeomorphism of the torus fixing the origin and R_0, R_1 real valued functions defined on \mathbb{T} .

Finally we consider the translation function

$$(A.5) \quad T_\lambda : \mathbb{T} \times \mathbb{R} \rightarrow \mathbb{T} \times \mathbb{R}, \quad (\theta, r) \mapsto (\beta + \theta, b + (1 + B) \cdot r) = (\theta, r) + \lambda,$$

having noted $\lambda = (\beta, b + B \cdot r)$.

We note Λ the space of translations $\Lambda = \{\lambda = (\beta, b + Br), \beta, b, B \in \mathbb{R}\}$.

THEOREM A.1. *Let α be Diophantine and $P^0 \in U(\alpha, A)$ be given. If Q is sufficiently close to P^0 , there exist a unique $(G, P, \lambda) \in \mathcal{G} \times U(\alpha, A) \times \Lambda$, close to $(\text{id}, P^0, 0)$, such that*

$$Q = T_\lambda \circ G \circ P \circ G^{-1}.$$

Whenever $\beta = 0 = B$, the curve $(\Theta, \gamma(\Theta))$, $\gamma = R_0 \circ \varphi^{-1}$, is translated by $b \in \mathbb{R}$ and the translated curve's dynamics is conjugated to the rotation $R_{2\pi\alpha}$. Rüssmann's theorem turns out to be a direct consequence (cf. section A.2).

The case of our interest will be when A close to 0, as whenever the normal hyperbolicity gets large with respect to the perturbation, one can prove the actual persistence of T_0 via the method of the graph transform.

A.1. Outline of the proof

A.1.1. Spaces of conjugacies. We extend manifolds with complex strip and consider \mathbb{T}_s and \mathbb{T}_s and endow them with the s -weighted norm $|\cdot|_s$.

- We recall that we indicate with $\mathcal{A}(U_s, V_{s'})$ the set of holomorphic functions from one complex extension to another and with $\mathcal{A}(U_s)$ the set of those with image in \mathbb{C} .
- We consider the set \mathcal{G}_s^σ of germs of holomorphic diffeomorphisms on \mathbb{T}_s such that

$$|\varphi - \text{id}|_s \leq \sigma$$

as well as

$$|R_0 + (R_1 - \text{id}) \cdot r|_s \leq \sigma.$$

- We endow the tangent space at the identity of \mathcal{G}_s^σ with the norm

$$|\dot{G}|_s = \max(|\dot{G}_1|_s, |\dot{G}_2|_s)$$

- Let $U_s(\alpha, A)$ be the subspace of $\mathcal{A}(\mathbb{T}_s, \mathbb{T}_{\mathbb{C}} \times \mathbb{C})$ of those diffeomorphisms P of the form

$$P(\theta, r) = (\theta + 2\pi\alpha + O(r), (1 + A) \cdot r + O(r^2)).$$

We will indicate with p_i and P_i the coefficients of the order- i term in r in θ and r -directions respectively.

- If $G \in \mathcal{G}_s^\sigma$ and P is a diffeomorphism over $G(\mathbb{T}_s)$ we define the following deformed norm

$$|P|_{G,s} := |P \circ G|_s.$$

A.1.2. The normal form operator. Thanks to theorem (C.1) and corollary(C.1.1) the following operator

$$(A.6) \quad \begin{array}{ll} \phi: \mathcal{G}_{s+\sigma}^\sigma \times U_{s+\sigma}(\alpha, A) \times \Lambda & \rightarrow \mathcal{A}(\mathbb{T}_s, \mathbb{T}_{\mathbb{C}} \times \mathbb{C}) \\ (G, P, \lambda) & \mapsto T_\lambda \circ G \circ P \circ G^{-1} \end{array}$$

is now well defined.

A.1.3. Difference equation on the torus.

LEMMA A.1.1. *Let α be Diophantine in the sense of (A.2), $g \in \mathcal{A}(\mathbb{T}_{s+\sigma})$ and let some constants $a, b \in \mathbb{R} \setminus \{0\}$ be given. There exist a unique $f \in \mathcal{A}(\mathbb{T}_s)$ of zero average and a unique $\lambda \in \mathbb{R}$ such that the following is satisfied*

$$(A.7) \quad \lambda + af(\theta + 2\pi\alpha) - bf(\theta) = g(\theta), \quad \lambda = \int_{\mathbb{T}} g.$$

In particular f satisfies

$$|f|_s \leq \frac{C}{\gamma\sigma^{\tau+1}} |g|_{s+\sigma},$$

C being a constant depending on τ .

PROOF. Developing in Fourier series one has

$$\lambda + \sum_k (a e^{i2\pi k\alpha} - b) f_k e^{ik\theta} = \sum_k g_k e^{ik\theta};$$

we get $\lambda = g_0 = \int_{\mathbb{T}} g$ and

$$f(\theta) = \sum_{k \neq 0} \frac{g_k}{a e^{i2\pi k\alpha} - b} e^{ik\theta}.$$

Remark that

$$\begin{aligned} |a e^{i2\pi k\alpha} - b|^2 &= (a - b)^2 \cos^2 \frac{2\pi k\alpha}{2} + (a + b)^2 \sin^2 \frac{2\pi k\alpha}{2} \\ &\geq (a + b)^2 \sin^2 \frac{2\pi k\alpha}{2} = (a + b)^2 \sin^2 \frac{2\pi(k\alpha - l)}{2}, \end{aligned}$$

with $l \in \mathbb{Z}$. Choosing $l \in \mathbb{Z}$ such that $\frac{2\pi(k\alpha - l)}{2} \in [-\frac{\pi}{2}, \frac{\pi}{2}]$, we get

$$|a e^{i2\pi k\alpha} - b| \geq \frac{\pi^2}{4} |a + b| |k\alpha - l| \geq \frac{\pi^2}{4} |a + b| \frac{\gamma}{|k|^\tau},$$

using that $|\sin x| \geq \frac{\pi}{2}|x|$, $x \in [-\frac{\pi}{2}, \frac{\pi}{2}]$ and condition (A.2). Hence the lemma. \square

We address the reader interested to optimal estimates to [Rüs76].

A.1.4. Inversion of ϕ' and bound of ϕ'' .

PROPOSITION A.1.1. *Let $0 < s_0 < s < s + \sigma$. There exists ε_0 such that if $(G, P, \lambda) \in \mathcal{G}_{s_0}^{\varepsilon_0} \times U_{s+\sigma}(\alpha, A) \times \Lambda$, for all $\delta Q \in \mathcal{A}(\mathbb{T}_{s+\sigma}, \mathbb{T}_{\mathbb{C}} \times \mathbb{C})$, there exists a unique triplet $(\delta G, \delta P, \delta \lambda) \in T_G \mathcal{G}_s \times \overrightarrow{U_s}(\alpha, A) \times \Lambda$ such that*

$$(A.8) \quad \phi'(G_s, P, \lambda) \cdot (\delta G, \delta P, \delta \lambda) = \delta Q.$$

Moreover we have the following estimates

$$(A.9) \quad \max(|\delta G|_s, |\delta P|_s, |\delta \lambda|) \leq \frac{C'}{\sigma^{\tau'}} |\delta Q|_{G,s},$$

C' being a constant depending on $|x|_{s+\sigma}$.

PROOF. We have

$$\delta(T_\lambda \circ G \circ P \circ G^{-1}) = T_{\delta\lambda} \circ (G \circ P \circ G^{-1}) + T'_\lambda \circ (G \circ P \circ G^{-1}) \cdot \delta(G \circ P \circ G^{-1})$$

hence

$$M \cdot (\delta G \circ P + G' \circ P \cdot \delta P - G' \circ P \cdot P' \cdot G'^{-1} \cdot \delta G) \circ G^{-1} = \delta Q - T_{\delta\lambda} \circ (G \circ P \circ G^{-1}),$$

where $M = \begin{pmatrix} 1 & 0 \\ 0 & 1 + B \end{pmatrix}$ is T'_λ .

Pre-composing by G we get

$$M \cdot (\delta G \circ P + G' \circ P \cdot \delta P - G' \circ P \cdot P' \cdot G'^{-1} \cdot \delta G) = \delta Q \circ G - T_{\delta\lambda} \circ G \circ P;$$

multiplying both sides by $(G'^{-1} \circ P)M^{-1}$, and recalling that $\dot{G} = G'^{-1} \cdot \delta G$ we finally obtain

$$(A.10) \quad \dot{G} \circ P + \delta P - P' \cdot \dot{G} = G'^{-1} \circ P \cdot M^{-1} \delta Q \circ G + G'^{-1} \circ P \cdot M^{-1} T_{\delta\lambda} \circ G \circ P.$$

We remark that the term containing $T_{\delta\lambda}$ is no constant; expanding along $r = 0$, it reads

$$T_\lambda = G'^{-1} \circ P \cdot M^{-1} \cdot T_{\delta\lambda} \circ G \circ P = (\dot{\beta} + O(r), \dot{b} + \dot{B} \cdot r + O(r^2)).$$

The vector field \dot{G} reads

$$\dot{G}(\theta, r) = (\dot{\varphi}(\theta), \dot{R}_0(\theta) + \dot{R}_1(\theta) \cdot r).$$

The problem is now: G, λ, P, Q being given, find $\dot{G}, \delta P$ and $\dot{\lambda}$, hence $\delta\lambda$ and δg .

We are interested in solving the equation up to the 0-order in r in the θ -direction, and up to the first order in r in the action direction; hence we consider the Taylor expansions along T_0 to the needed order.

We remark that since $\delta P = (O(r), O(r^2))$, it will not intervene in the cohomological equations given out by (A.10), but will be uniquely determined by identification of the reminders.

Let us proceed to solve the equation (A.10), which splits into the following three

$$\dot{\varphi}(\theta + 2\pi\alpha) - \dot{\varphi}(\theta) + p_1 \cdot \dot{R}_0 = \dot{q}_0 + \dot{\beta}$$

$$\dot{R}_0(\theta + 2\pi\alpha) - (1 + A)\dot{R}_0(\theta) = \dot{Q}_0 + \dot{b}$$

$$(1 + A)\dot{R}_1(\theta + 2\pi\alpha) - (1 + A)\dot{R}_1(\theta) = \dot{Q}_1 - (2P_2 \cdot \dot{R}_0 + \dot{R}_0(\theta + 2\pi\alpha) \cdot p_1) + \dot{B}.$$

The first equation is the one straightening the tangential dynamics, while the second and the third are meant to relocate the torus and straighten the normal dynamics.

For the moment we solve the equations "modulo $\dot{\lambda}$ ". According to lemma (A.1.1), these three equations admit unique analytic solutions once the right hand side is average free.

– First, second equation has a solution

$$\dot{R}_0 = L_\alpha^{-1}(\dot{Q}_0 + \dot{b} - \bar{b}),$$

with

$$\bar{b} = \int_{\mathbb{T}} \dot{Q}_0 + \dot{b} \frac{d\theta}{2\pi},$$

and

$$|\dot{R}_0|_s \leq \frac{C}{(2+A)\gamma^2\sigma^{\tau+1}} |\dot{Q}_0 + \dot{b}|_{s+\sigma}.$$

– Second, we have

$$\dot{\varphi}(\theta + 2\pi\alpha) - \dot{\varphi}(\theta) + p_1 \cdot \dot{R}_0 = \dot{q}_0 + \dot{\beta} - \bar{\beta},$$

with $\bar{\beta} = \int_{\mathbb{T}} \dot{q}_0 - p_1 \cdot R_0 + \dot{\beta} \frac{d\theta}{2\pi}$, hence

$$\dot{\varphi} = L_\alpha^{-1}(\dot{q}_0 + \dot{\beta} - \bar{\beta}),$$

satisfying

$$|\dot{\varphi}|_{s-\sigma} \leq \frac{C}{\gamma\sigma^{\tau+2}} |\dot{q}_0 + \dot{\beta}|_{s+\sigma}$$

– Third, the solution of equation in \mathbb{R}_1 is

$$\dot{R}_1 = L_\alpha^{-1}(\tilde{Q}_1 + \dot{B} - \bar{B}),$$

having noted $\tilde{Q}_1 = \dot{Q}_1 - (2P_2 \cdot \dot{R}_0 + \dot{R}_0(\theta + 2\pi\alpha) \cdot p_1)$, satisfies

$$|\dot{R}_1|_{s-\sigma} \leq \frac{C}{(2+2A)\gamma\sigma^{1+\tau}} |\tilde{Q}_1 - \dot{B}|_{s+\sigma}.$$

We now handle the unique choice of $\delta\lambda = (\delta\beta, \delta b + \delta B \cdot r)$ occurring in the translation map $T_{\delta\lambda}$. If $\bar{\lambda} = (\bar{\beta}, \bar{b} + \bar{B} \cdot r)$, the map $f : \Lambda \rightarrow \Lambda$, $\delta\lambda \mapsto \bar{\lambda}$ is well defined. In particular when $G = \text{id}$, $\frac{\partial f}{\partial \delta\lambda} = -\text{id}$ and it will remain bounded away from 0 if G stays sufficiently close to the identity: $|G - \text{id}|_{s_0} \leq \varepsilon_0$, for $s_0 < s$. In particular, $-\bar{\lambda}$ is affine in $\delta\lambda$, the system to solve being triangular of the form $\int_{\mathbb{T}^n} a(G, \dot{v}) + A(G) \cdot \delta\lambda = 0$, with diagonal close to 1 if the smallness condition above is assumed. Under these conditions f is a local diffeomorphism and $\delta\lambda$ such that $f(\delta\lambda) = 0$ is then uniquely determined, and

$$|\delta\lambda| \leq \frac{C}{\sigma^{\tau+1}} |\delta Q|_{G, s+\sigma}.$$

Now, from the definition of $\dot{G} = G'^{-1} \cdot \delta G$ we get $\delta G = G' \cdot \dot{G}$, hence similar estimates hold for δG :

$$|\delta G|_{s-\sigma} \leq \frac{C}{\sigma^{\tau+2}} (1 + |G' - \text{id}|_{s-\sigma}) |\delta Q|_{G, s+\sigma} \leq \frac{C}{\sigma^{\tau+3}} |\delta Q|_{G, s+\sigma}.$$

Equation (A.10) uniquely determines δP .

Up to redefining $\sigma' = \sigma/2$ and $s' = s + \sigma$, we have the wanted estimates for all $s', \sigma' : s' < s' + \sigma'$. \square

A.1.5. Second derivative. We consider the bilinear map $\phi''(x)$. We have

LEMMA A.1.2 (Boundness of ϕ''). *The bilinear map $\phi''(x)$*

$$\phi''(x) : (T_G \mathcal{G}_{s+\sigma}^\sigma \times \overrightarrow{U_{s+\sigma}(\alpha, A)} \times \Lambda)^{\otimes 2} \rightarrow \mathcal{A}(\mathbb{T}_s, \mathbb{T}_{\mathbb{C}} \times \mathbb{C}),$$

satisfies the estimates

$$|\phi''(x) \cdot \delta x^{\otimes 2}|_{G,s} \leq \frac{C''}{\sigma^{\tau''}} |\delta x|_{s+\sigma}^2,$$

C'' being a constant depending on $|x|_{s+\sigma}$.

PROOF. Differentiating twice ϕ we get

$$\begin{aligned} & -M\{[\delta G' \circ P \cdot \delta P + \delta G' \circ P \cdot \delta P + G'' \circ P \cdot \delta P^2 - (\delta G' \circ P + G'' \circ P \cdot \delta P) \cdot P' \cdot G'^{-1} \cdot \delta G \\ & \quad - G' \circ P \cdot (\delta P' \cdot (-G'^{-1} \cdot \delta G' \cdot G'^{-1}) \cdot \delta G)] \circ G^{-1} + \\ & \quad + [\delta G' \circ P \cdot \delta P + \delta G' \circ P \cdot \delta P + G'' \circ P \cdot \delta P^2 - (\delta G' \circ P + G'' \circ P \cdot \delta P) \cdot P' \cdot G'^{-1} \cdot \delta G \\ & \quad - G' \circ P \cdot (\delta P' \cdot (-G'^{-1} \cdot \delta G' \cdot G'^{-1}) \cdot \delta G)]' \circ G^{-1} \cdot (-G'^{-1} \cdot \delta G) \circ G^{-1}\}. \end{aligned}$$

Once we precompose with G , the estimate follows. \square

A.1.6. Final step. Notations are the same as in section 1.4.

Let note $E_s = \mathcal{G}_{s+\sigma} \times U_{s+\sigma}(\alpha, A) \times \Lambda$, $F_s = \mathcal{A}(\mathbb{T}_s, \mathbb{T}_{\mathbb{C}} \times \mathbb{C})$. The respective decreasing families $(E_s)_{s>0}$ and $(F_s)_{s>0}$ of Banach spaces carrying increasing norms $|\cdot|_s$. On F_s we consider the already introduced deformed norm depending on $x \in E_s$ (which in our case corresponds to the dependence on the transformation G):

$$|y|_{0,s} = |y|_s, \quad |y|_{x,s} \leq |y|_{x',s+|x-x'|_s}.$$

Indicating with $B_{s+\sigma}^E(\sigma)$ the ball centered at $x_0 = (\text{id}, P^0, 0)$ in $E_{s+\sigma}$, the operator $\phi(x)$, $x \in E_{s+\sigma}$, commuting with inclusions, is twice differentiable and $\phi'(x)$ possesses a right and left inverse $\phi'^{-1}(x)$.

Hypothesis of theorem 1.4 are satisfied; theorem A.1 follows.

A.2. The translated curve of Rüssmann

The diffeomorphisms considered by Rüssmann are of this kind in a neighborhood of \mathbb{T}_0

$$(A.11) \quad Q(\theta, r) = (\theta + 2\pi\alpha + t(r) + f(\theta, r), (1 + A)r + g(\theta, r)),$$

where α is Diophantine, $t(0) = 0$ and $t'(r) > 0$ for every r . This represents a perturbation of

$$P^0(\theta, r) = (\theta + \alpha + t(r), (1 + A)r),$$

for which \mathbb{T}_0 is invariant and carries a rotation $2\pi\alpha$.

THEOREM A.2 (Rüssmann). *Fix $\alpha \in D_{\gamma, \tau}$ and*

$$P^0(\theta, r) = (\theta + 2\pi\alpha + t(r) + O(r^2), (1 + A)r + O(r^2)) \in U(\alpha, A)$$

such that $t(0) = 0$ and $t'(r) > 0$.

If Q is close enough to P^0 there exists a unique analytic curve $\gamma \in \mathcal{A}(\mathbb{T}, \mathbb{R})$, close to $r = 0$, a diffeomorphism φ of \mathbb{T} close to the identity and $b \in \mathbb{R}$, close to 0, such that

$$Q(\theta, \gamma(\theta)) = (\varphi \circ R_{2\pi\alpha} \circ \varphi^{-1}(\theta), b + \gamma(\varphi \circ R_{2\pi\alpha} \circ \varphi^{-1}(\theta))).$$

Actually in its original version the theorem is stated for $A = 0$; to consider the more general case with A close to 0, does not bring any further difficulties.

To deduce Rüssmann's theorem from theorem A.1 we need to get rid of the counter-terms β and B .

A.2.1. Elimination of B . In order to deduce Rüssmann's result from theorem (A.1) we need to reduce the number of translation terms of T_λ to one, corresponding to the translation in the r -direction ($T_{\lambda=(0,b)}$). As we are not interested in keeping the same normal dynamics of the perturbed diffeomorphism Q , up to let A vary and conjugate Q to some well chosen P_A , we can indeed make the counter term $B \cdot r$ to be zero.

Let $\Lambda_2 = \{\lambda = (\beta, b), \beta, b \in \mathbb{R}\}$.

PROPOSITION A.2.1. *For every $P^0 \in U_{s+\sigma}(\alpha, A_0)$ with α diophantine, there is a germ of C^∞ maps*

$$\psi : \mathcal{A}(\mathbb{T}_{s+\sigma}, \mathbb{T}_{\mathbb{C}} \times \mathbb{C}) \rightarrow \mathcal{G}_s \times U_s(\alpha, A) \times \Lambda_2, \quad Q \mapsto (G, P, \lambda),$$

at $P^0 \mapsto (\text{id}, P^0, 0)$, such that $Q = T_\lambda \circ G \circ P \circ G^{-1}$.

PROOF. Denote ϕ_A the operator ϕ , as now we want A to vary. Let us write P^0 as

$$P^0(\theta, r) = (\theta + 2\pi\alpha + O(r), (1 + A_0 - \delta A) \cdot r + \delta A \cdot r + O(r^2)),$$

and remark that

$$P^0 = T_\lambda \circ P_A, \quad \lambda = \left(0, B \cdot r = \left(-\delta A + \frac{\delta A \cdot A_0}{1 + A_0}\right) \cdot r\right),$$

where $P_A = (\theta + 2\pi\alpha + O(r), (1 + A) \cdot r + O(r^2))$ ¹ with

$$A = \left(A_0 + \frac{\delta A(1 + A_0)}{1 + A_0 - \delta A}\right).$$

According to theorem A.1, $\phi_A(\text{id}, P_A, \lambda) = P^0$. In particular

$$\frac{\partial B}{\partial \delta A}|_{G=\text{id}} = -\text{id} + \frac{A_0}{1 + A_0},$$

¹The terms $O(r)$ and $O(r^2)$ contain a factor $(1 + \frac{\delta A}{1 + A_0 - \delta A})$

where A_0 is close to 0. Hence, defining

$$\hat{\psi} : \mathbb{R} \times \mathcal{A}(\mathbb{T}_{s+\sigma}, \mathbb{T}_{\mathbb{C}} \times \mathbb{C}) \rightarrow \mathcal{G}_s \times U_s(\alpha, A) \times \Lambda, (A, Q) \mapsto \hat{\psi}_A(Q) := \phi_A^{-1}(Q) = (G, P, \lambda)$$

in the neighborhood of (A_0, P^0) , by the implicit function theorem locally for all Q there exists a unique \bar{A} such that $B(\bar{A}, Q) = 0$. It remains to define $\psi(Q) = \hat{\psi}(\bar{A}, Q)$. \square

Whenever the interest lies on the translation of the curve and the dynamics tangential to it, do not care about the "final" A and consider the situation that puts $B = 0$.

In particular the graph of $\gamma(\theta) := R_0 \circ \varphi^{-1}(\theta)$ is translated by b and its dynamics is conjugated to $R_{2\pi\alpha}$, modulo the term β :

$$Q(\theta, \gamma(\theta)) = (\beta + \varphi \circ R_{2\pi\alpha} \circ \varphi^{-1}(\theta), b + \gamma(\varphi \circ R_{2\pi\alpha} \circ \varphi^{-1}(\theta))).$$

A.2.2. A family of translated curves. Theorem A.1 guarantees that any given diffeomorphism Q , sufficiently close to P^0 (see equation (A.3)), is of the form $Q = T_\lambda \circ G \circ P \circ G^{-1}$, with G , P and T_λ uniquely determined, implying the existence of a curve whose image by Q is translated. Actually there exists a whole family of translated curves. Indeed, let us consider a parameter $c \in B_1(0)$ (the unit ball in \mathbb{R}) and the family of diffeomorphisms $Q_c(\theta, r) := Q(\theta, c+r)$ relative to the given Q . Considering the corresponding normal form operators ϕ_c , the parametrized version of theorem A.1 follows readily.

Now, if Q_c is close enough to P^0 , proposition A.2.1 asserts the existence of $(G_c, P_c, \lambda_c) \in \mathcal{G} \times U(\alpha, A) \times \Lambda_2$ such that

$$Q_c = T_\lambda \circ G_c \circ P_c \circ G_c^{-1}.$$

Hence we have a family of curves parametrized by $\tilde{c} = c + \int_{\mathbb{T}} \gamma \frac{d\theta}{2\pi}$,

$$Q(\theta, \tilde{c} + \tilde{\gamma}(\theta)) = (\beta + \varphi \circ R_{2\pi\alpha} \circ \varphi^{-1}(\theta), b + \tilde{c} + \tilde{\gamma}(\varphi \circ R_{2\pi\alpha} \circ \varphi^{-1}(\theta))),$$

where $\tilde{\gamma} = \gamma - \int_{\mathbb{T}} \gamma \frac{d\theta}{2\pi}$.

A.2.3. Torsion property: elimination of β . As we have seen in the last section, under smallness and diophantine conditions on Q , there exists a family of curves, parametrized by c , whose images are translated by b in the r -direction and whose tangential dynamics is conjugated to the rotation $R_{2\pi\alpha}$, modulo the term $\beta \in \mathbb{R}$.

In order to get the dynamical conjugacy to the rotation stated by Rüssmann's theorem, it is of fundamental importance for Q to satisfy some torsion property, and this is provided by the request that $t'(r) > 0$ for every r . Once this property is satisfied, in the light of the previous section, in order to prove Rüssmann's theorem it suffices to show that there exists a unique c close to 0 such that $\beta = \beta(c) = 0$.

We want to show that the map $c \mapsto \beta(c)$ is a local diffeomorphism.

It suffices to show this for the trivial perturbation P_c^0 . The Taylor expansion of P_c^0 directly gives $c \mapsto \beta(c) = t(c) + O(c^2)$, which is a local diffeomorphism due to the torsion hypothesis on Q . Hence, the analogous map for Q_c , is a small perturbation of the previous one, hence a local diffeomorphism too. Then there exists a unique $c \in \mathbb{R}$ such that $\beta(c) = 0$.

In dimension higher than 2, the analogue of Rüssmann's theorem could not be possible: needing the matrix $B \in \text{Mat}_n(\mathbb{R})$, $n \geq 2$, to solve the third homological equation and disposing of just n characteristic exponents of A that we may vary as we did in the last sections, it is hopeless to kill the whole B . As a consequence, the obtained surface will undergo more than a simple translation.

Let now $U(\alpha, A)$ be the space of germs of diffeomorphisms along $T_0^n \subset \mathbb{T}^n \times \mathbb{R}^m$ of the form

$$P(\theta, r) = (\theta + 2\pi\alpha + T(r) + O(r^2), (1 + A) \cdot r + O(r^2)),$$

where $A \in \text{Mat}_m(\mathbb{R})$ is a diagonalizable matrix of real eigenvalues $a_j \neq 0$ and $T(r)$ is such that $T(0) = 0$ and $T'(r)$ is invertible for all $r \in \mathbb{R}^m$.

Let also \mathcal{G} be the space of germs of real analytic isomorphisms of the form $g(\theta, r) = (\varphi(\theta), R_0(\theta) + R_1(\theta) \cdot r)$, φ being a diffeomorphism of \mathbb{T}^n fixing the origin, R_0 and R_1 an \mathbb{R}^m -valued and $\text{Mat}_m(\mathbb{R})$ -valued functions defined on \mathbb{T}^n .

Let $\Lambda_{m^2} = \{\lambda = (0, b + B \cdot r), b \in \mathbb{R}^m, B \in \text{Mat}_m(\mathbb{R})\}$, where $B \in \text{Mat}_m(\mathbb{R})$ has $m^2 - m$ entries different from 0.

THEOREM A.3. *Let α be Diophantine. If Q is sufficiently close to $P^0 \in U(\alpha, A_0)$, there exists a unique $(G, P, \lambda) \in \mathcal{G} \times U(\alpha, A) \times \Lambda_{m^2}$, close to $(\text{id}, P^0, 0)$ such that*

$$Q = T_\lambda \circ G \circ P \circ G^{-1}.$$

The proof follows from the generalization in dimension ≥ 2 (which is not hard to recover) of the previous results.

A.2.4. Curves C_α for general perturbations of the unperturbed spin-orbit flow. With no further assumptions on Q , one cannot expect that the translation b vanishes in some circumstances. If in the case of vector fields relative to the spin-orbit problem, the Hamiltonian structure of equations and the dependence on the external parameter $\nu \in \mathbb{R}$ has been the key point to kill the counter term b and obtain the dynamical conjugacy, in this study we consider generic analytic perturbation of the time 2π -map

relative to the unperturbed spin-orbit equations:

$$Q(\theta, \tilde{\rho}) = \left(\theta + 2\pi\alpha + \frac{1 - e^{-2\pi\eta}}{\eta} \tilde{\rho} + \varepsilon f(\theta, \tilde{\rho}), e^{-2\pi\eta} \tilde{\rho} + \tau + \varepsilon g(\theta, \tilde{\rho}) \right).$$

In this case, nothing ensures that the C_α portrayed in the very particular context of the vector-field of the spin-orbit, exist and reach the $\eta = 0$ axis (the hamiltonian axes). If these curves are not expected to exist for every value of η and ε , we can still guarantee their existence provided η being not too small.

As a matter of fact, we notice that when no perturbation occurs Q reduces to

$$Q(\theta, \tilde{\rho}) = \left(\theta + 2\pi\alpha + \frac{1 - e^{-2\pi\eta}}{\eta} \tilde{\rho}, e^{-2\pi\eta} \tilde{\rho} + \tau \right),$$

and the circle $\tilde{\rho} = 0$ undergoes the translation $b := \tau = 2\pi\eta(\nu - \alpha)$. For the unique choice of the parameter $\nu = \alpha$, \mathbb{T}_0 is invariant.

Rüssmann's theorem A.2 applied to the perturbation Q asserts the existence, for all $\varepsilon \leq \varepsilon_0$ (ε_0 being the maximal admissible perturbation), a unique curve γ , a diffeomorphism φ and a translation function b such that considering the variables change

$$(\theta, \tilde{\rho}) \mapsto (h^{-1}(\theta) = \xi, \tilde{\rho} - \gamma(\theta) = x)$$

we transform Q in the form

$$Q(\xi, x) = (\xi + 2\pi\alpha + O(x), b + e^{-2\pi\eta}x + O(x)).$$

Considering the map $\nu \mapsto b$ it is evident that $\frac{\partial b}{\partial \nu}|_{\varepsilon=0} = 2\pi\eta \neq 0$.

Because of the uniform convergence and the smallness condition on ε uniform with respect to parameters, the limit solution b keeps its real analytic dependence on ε , and smoothness with respect to η, ν .

Considering the map $\mathbb{R}^3 \ni (\varepsilon, \nu, \eta) \mapsto b(\varepsilon, \nu, \eta)$ we already know that at $p_0 = (0, \alpha, \eta)$ we have $b(p_0) = 0$ and that $\frac{\partial b}{\partial \nu}|_{\varepsilon=0} = 2\pi\eta > \pi\eta > 0$.

In order to have $b = 0$ when $\varepsilon \neq 0$, we need to guarantee that its differential with respect to ν remains bounded away from 0. But this can be seen as follows.

Let us consider the closed ball of radius ε_0 centered at $p_0 \in \mathbb{R}^3$ and call it $B_{\varepsilon_0}(p_0)$. Because of the regularity of b with respect to ε, ν and η , there exists a positive constant M independent of ε, η, ν such that $\|b\|_{C^2} < M$. Let now consider a ball of radius $\varepsilon < \varepsilon_0$. The mean value theorem applied to the function $\frac{\partial b}{\partial \nu}$ guarantees $\forall p_2, p_1 \in B_{\varepsilon/2}(p_0)$ that

$$\left| \frac{\partial b}{\partial \nu}(p_2) - \frac{\partial b}{\partial \nu}(p_1) \right| \leq \int_0^1 \left| D \frac{\partial b}{\partial \nu}(p_t) \right| |p_1 - p_2| dt \leq M |p_2 - p_1|,$$

$|\cdot|$ indicating the supremum norm. By the triangular inequality we obtain

$$\left| \frac{\partial b}{\partial \nu}(p_2) \right| \geq \left| \frac{\partial b}{\partial \nu}(p_1) \right| - M\varepsilon,$$

in particular fixing $p_1 = p_0$, a sufficient condition for having $|\frac{\partial b}{\partial \nu}(p_2)| > \pi\eta$ is that $\pi\eta/4M > \varepsilon$.

Hence, for every fixed value of ε , we can guarantee that the derivative of b with respect to ν is different from 0, for those η 's such that $\eta \geq \varepsilon 4M/\pi$, this guarantees us to find ν such that $b(\nu, \varepsilon, \eta) = 0$ whenever this condition on η is fulfilled.

APPENDIX B

Hypothetical conjugacy and translated torus theorem

In section 2.4, we proved a sort of Rüssmann's theorem for dissipative vector fields of type $v^H \oplus (-\eta(r - \Omega)\partial_r)$, Ω being an external parameter (the proper frequency of the attractor of the unperturbed dynamics) varying in the unit ball of \mathbb{R}^n . For the sake of completeness we mention here another result of this kind, in a more general context, which follows from the hypothetical conjugacy theorem of Féjóz [Féj04, Section 4.4] adapted to vector fields in Moser's normal form.

In this purpose it is convenient to extend the inverse of the normal form operator ϕ to non Diophantines frequencies (α, A) . The constructed map ψ , inverse of $\phi : (g, u, \lambda) \mapsto g_*u + \lambda$, is actually C^1 in the sense of Whitney, with respect to parameters (α, A) , and thus admits an extension.

Let us call $\nu = (\alpha_1, \dots, \alpha_n, a_1, \dots, a_n)$ the vector of characteristic frequencies, and suppose that $\nu \in B_1^{2n}$, the unit ball in \mathbb{R}^{2n} .

Let us indicate with ϕ_ν the normal form operator as now we want frequencies to vary. The corresponding inverse is analogously indicated with ψ_ν .

Let assume that ϕ'_ν is C^1 with respect to ν and that estimates on ϕ'^{-1}_ν and ϕ''_ν are uniform with respect to ν over some closed subset D of \mathbb{R}^{2n} .

PROPOSITION B.0.1 (C^1 -Whitney differentiability). *Let us fix ε as in proposition 1.4.1. The map $\psi : D \times B_{s+\sigma}^F(\varepsilon) \rightarrow B_s^E(\eta)$ is C^1 - Whitney differentiable and extends to a map $\psi : \mathbb{R}^{2n} \times B_{s+\sigma}^F(\varepsilon) \rightarrow B_s^E(\eta)$ of class C^1 .*

The proof strongly relies on the Lipschitz property of ψ , proven in proposition 1.4.1.

PROOF. Let $y \in B_{s+\sigma}^F(\varepsilon)$. For $\nu, \nu + \mu \in D$, let $x_\nu = \psi_\nu(y)$ and $x_{\nu+\mu} = \psi_{\nu+\mu}(y)$, implying

$$\phi_{\nu+\mu}(x_{\nu+\mu}) - \phi_{\nu+\mu}(x_\nu) = \phi_\nu(x_\nu) - \phi_{\nu+\mu}(x_\nu).$$

It then follows, since $y \mapsto \psi_{\nu+\mu}(y)$ is Lipschitz, that

$$|x_{\nu+\mu} - x_\nu|_s \leq L|\phi_\nu(x_\nu) - \phi_{\nu+\mu}(x_\nu)|_{x_\nu, s+\sigma},$$

taking $y = \phi_{\nu+\mu}(x_\nu)$, $\hat{y} = \phi_{\nu+\mu}(x_{\nu+\mu})$. In particular since $\nu \mapsto \phi_\nu(x_\nu)$ is Lipschitz, the same is for $\nu \mapsto x_\nu$. Let us now expand $\phi_{\nu+\mu}(x_{\nu+\mu}) = \phi(\nu + \mu, x_{\nu+\mu})$

in Taylor at (ν, x_ν) . We have

$$\phi(\nu + \mu, x_{\nu+\mu}) = \phi(\nu, x_\nu) + D\phi(\nu, x_\nu) \cdot (\mu, x_{\nu+\mu} - x_\nu) + O(\mu^2, |x_{\nu+\mu} - x_\nu|_s^2),$$

hence formally defining the derivative $\partial_\nu x_\nu := -\phi'_\nu{}^{-1}(x_\nu) \cdot \partial_\nu \phi_\nu(x_\nu)$, we obtain

$$x_{\nu+\mu} - x_\nu - \partial_\nu x_\nu \cdot \mu = \phi'_\nu{}^{-1}(x_\nu) \cdot O(\mu^2),$$

hence

$$|x_{\nu+\mu} - x_\nu - \partial_\nu x_\nu \cdot \mu|_s = O(\mu^2)$$

by Lipschitz property of $\nu \mapsto x_\nu$, when $\mu \mapsto 0$, locally uniformly with respect to ν . Hence $\nu \mapsto x_\nu$ is C^1 -Whitney-smooth and the claimed extension exists (see [AR67] for the proof of this extension in the case of interest to us: ψ takes values in a Banach space. Note that the extension direction is of finite dimension though.) \square

For simplicity, let A be already in its diagonal form and note a the vector of its eigen values, corresponding to vector fields $u \in \mathcal{U}(\alpha, A)$ and define

$$\mathcal{U} = \coprod_{(\alpha, a) \in \mathbb{R}^n \times \mathbb{R}^n} \mathcal{U}(\alpha, A).$$

THEOREM B.1 (Hypothetical translated torus). *For any $u^0 \in \mathcal{U}$, locally in its neighborhood there exists a germ of C^∞ map*

$$\psi : (\mathcal{V}_{s+\sigma}, u^0) \rightarrow (\mathcal{U}_s \times \mathcal{G}_s \times \mathbb{R}^n, (u^0, \text{id}, 0)), v \mapsto (g, u, \lambda)$$

such that if (α, a) are Diophantine in the sense of (1.5), then $v = g_* u + b$, $b \in \mathbb{R}^n$.

The conjugacy g giving the translated torus is rightfully called "hypothetical" because its existence is subordinated to the arithmetic condition that (α, a) , a priori unknown, have to satisfy. For example, let assume that the unperturbed vector field $u^0 \in \mathcal{U}(\alpha, A)$ depends on some parameter $s \in \mathbb{R}^S$. In Celestial mechanics this parameter could be the length of the semi-major axes or, in the purely Hamiltonian context of Kolmogorov, the action coordinates. So, in particular the perturbed frequencies smoothly depend on this parameter. The main point consists in measuring the set of $s \in \mathbb{R}^S$ for which the Whitney extension of the perturbed frequencies $s \mapsto (\alpha_s, a_s)$, which is close to the unperturbed one $s \mapsto (\alpha_s^0, a_s^0)$, is Diophantine. Hence if this last satisfy some open property that implies a big measure for the corresponding set of s , the same will be for the perturbed one.

PROOF. Let us introduce ϕ_ν the operator depending on frequencies (α, a) , and define the map

$$\hat{\psi} : D_{\gamma, \tau} \times \mathcal{V}_{s+\sigma} \rightarrow \mathcal{U}_s(\alpha, A) \times \mathcal{G}_s \times \Lambda, \hat{\psi}_\nu(v) := \phi'_\nu{}^{-1}(v) = (g, u, \lambda)$$

locally in the neighborhood of $((\alpha^0, a^0), u^0)$, $u^0 \in \mathcal{U}(\alpha^0, A^0)$. Since ϕ_ν is differentiable, there exists an extension of $\hat{\psi}$

$$\hat{\psi} : \mathbb{R}^{2n} \times \mathcal{V}_{s+\sigma} \rightarrow \mathcal{U}_s(\alpha, A) \times \mathcal{G}_s \times \Lambda.$$

Let us now artificially write u^0 as

$$u^0 = u(\alpha, A) + (\alpha^0 - \alpha, (A^0 - A) \cdot r),$$

for the uniqueness of the normal form we have

$$\hat{\psi}(u^0) = (u, \text{id}, \lambda), \quad \lambda = (\Delta\alpha, \Delta A \cdot r).$$

In particular,

$$\left. \frac{\partial \lambda}{\partial(\alpha, A)} \right|_{g=\text{id}} = -\text{id},$$

and by the implicit function theorem (in finite dimension) for all v sufficiently close to u^0 there exists unique $\hat{v} = (\hat{\alpha}, \hat{a})$ such that $\lambda(\hat{\alpha}, \hat{A}, b) = (0, b)$. It remains to define $\psi(v) = \hat{\psi}(\hat{v}, v)$. \square

COROLLARY B.0.1 (Hypothetical conjugacy). *If $u^0 = (\alpha^0 + O(r), A^0 \cdot r + O(r^2))$ is such that the eigen values of A^0 are all different from 0 and pairwise distinct, locally in its neighborhood there exists a germ of C^∞ map*

$$\psi : (\mathcal{V}_{s+\sigma}, u^0) \rightarrow (\mathcal{U}_s \times \mathcal{G}_s, (u^0, \text{id})), \quad v \mapsto (u, g)$$

such that if (α, a) are Diophantine in the sense of (1.5), then $v = g_ u$.*

APPENDIX C

Classical results

We present here a classical result on the inversion of holomorphisms on the complex torus \mathbb{T}_s^n that intervened to guarantee the well definition of normal form operators ϕ . Moreover, we give the explicit differentiation of some important maps that we considered; we stress the fact that since the beginning we endowed every space considered with analytic norms and saw it as Banach.

C.1. Inversion of a holomorphism of \mathbb{T}_s^n

As in the all manuscript the complex extensions of manifolds are defined at the help of the ℓ^∞ -norm,

$$\mathbb{T}_s^n = \left\{ \theta \in \mathbb{T}_{\mathbb{C}}^n : |\theta| := \max_{1 \leq j \leq n} |\operatorname{Im} \theta_j| \leq s \right\}.$$

Let also define $\mathbb{R}_s^n := \mathbb{R}^n \times (-s, s)$ and consider the universal covering of \mathbb{T}_s^n , $p: \mathbb{R}_s^n \rightarrow \mathbb{T}_s^n$.

THEOREM C.1. *Let $v: \mathbb{T}_s^n \rightarrow \mathbb{C}^n$ be a vector field such that $|v|_s < \sigma/n$. The map $\operatorname{id} + v: \mathbb{T}_{s-\sigma}^n \rightarrow \mathbb{R}_s^n$ induces a map $\varphi = \operatorname{id} + v: \mathbb{T}_{s-\sigma}^n \rightarrow \mathbb{T}_s^n$ which is a biholomorphism and there is a unique biholomorphism $\psi: \mathbb{T}_{s-2\sigma}^n \rightarrow \mathbb{T}_{s-\sigma}^n$ such that $\varphi \circ \psi = \operatorname{id}_{\mathbb{T}_{s-2\sigma}^n}$.*

In particular the following hold:

$$|\psi - \operatorname{id}|_{s-2\sigma} \leq |v|_{s-\sigma}$$

and, if $|v|_s < \sigma/2n$

$$|\psi' - \operatorname{id}|_{s-2\sigma} \leq \frac{2}{\sigma} |v|_s.$$

PROOF. Let $\hat{\varphi} := \operatorname{id} + v \circ p: \mathbb{R}_s^n \rightarrow \mathbb{R}_{s+\sigma}^n$ be the lift of φ to \mathbb{R}_s^n . Let's start proving the injectivity and surjectivity of $\hat{\varphi}$; the same properties for φ descend from these.

– $\hat{\varphi}$ is injective as a map from $\mathbb{R}_{s-\sigma}^n \rightarrow \mathbb{R}_s^n$.

Let $\hat{\varphi}(x) = \hat{\varphi}(x')$, from the definition of $\hat{\varphi}$ we have

$$\begin{aligned} |x - x'| &= |v \circ p(x') - v \circ p(x)| \leq \int_0^1 \sum_{k=1}^n |\partial_{x_k} \hat{v}|_{s-\sigma} |x'_k - x_k| dt \leq \frac{n}{\sigma} |v|_s |x - x'| \\ &< |x - x'|, \end{aligned}$$

hence $x' = x$.

– $\hat{\varphi} : \mathbb{R}_{s-\sigma}^n \rightarrow \mathbb{R}_{s-2\sigma}^n \subset \hat{\varphi}(\mathbb{R}_{s-\sigma}^n)$ is surjective.

Define, for every $y \in \mathbb{R}_{s-2\sigma}^n$ the map

$$f : \mathbb{R}_{s-\sigma}^n \rightarrow \mathbb{R}_{s-\sigma}^n, x \mapsto y - v \circ p(x),$$

which is a contraction (see the last but one inequality of the previous step).

Hence there exists a unique fixed point such that $\hat{\varphi}(x) = x + v \circ p(x) = y$.

For every $k \in 2\pi\mathbb{Z}^n$, the function $\mathbb{R}_s^n \rightarrow \mathbb{R}_s^n, x \mapsto \hat{\varphi}(x+k) - \hat{\varphi}(x)$ is continuous and $2\pi\mathbb{Z}^n$ -valued. In particular there exists $A \in \text{GL}_n(\mathbb{Z})$ such that $\hat{\varphi}(x+k) = \hat{\varphi}(x) + Ak$.

– $\varphi : \mathbb{T}_{s-\sigma}^n \rightarrow \mathbb{T}_s^n$ is injective.

Let $\varphi(p(x)) = \varphi(p(x'))$, with $p(x), p(x') \in \mathbb{T}_{s-\sigma}^n$, hence $\hat{\varphi}(x') = \hat{\varphi}(x) + k' = \hat{\varphi}(x + k')$, for some $k' \in 2\pi\mathbb{Z}^n$, hence $x' = x + k'$, for the injectivity of $\hat{\varphi}$, thus $p(x) = p(x')$. In particular φ is biholomorphic:

LEMMA C.1.1 ([FG02]). *If $G \subset \mathbb{C}^n$ is a domain and $f : G \rightarrow \mathbb{C}^n$ injective and holomorphic, then $f(G)$ is a domain and $f : G \rightarrow f(G)$ is biholomorphic.*

– That $\varphi : \mathbb{T}_{s-\sigma}^n \rightarrow \mathbb{T}_{s-2\sigma}^n \subset \varphi(\mathbb{T}_{s-\sigma}^n)$ is surjective follows from the one of $\hat{\varphi}$.

– Estimate for $\psi : \mathbb{T}_{s-2\sigma}^n \rightarrow \mathbb{T}_{s-\sigma}^n$ the inverse of φ .

Let $\hat{\psi} : \mathbb{R}_{s-2\sigma}^n \rightarrow \mathbb{R}_{s-\sigma}^n$ be the inverse of $\hat{\varphi}$, and $y \in \mathbb{R}_{s-2\sigma}^n$. From the definition of $\hat{\varphi}$, $v \circ p(\hat{\psi}(y)) = y - p(\hat{\psi}(y)) = y - \hat{\psi}(y)$. Hence

$$|\hat{\psi}(y) - y|_{s-2\sigma} = |v \circ p(\hat{\psi}(y))|_{s-2\sigma} \leq |v|_{s-2\sigma} \leq |v|_{s-\sigma}.$$

– Estimate for $\psi' = \varphi'^{-1} \circ \varphi^{-1}$. We have

$$|\psi' - \text{id}|_{s-2\sigma} \leq |\varphi'^{-1} - \text{id}|_{s-\sigma} \leq \frac{|\varphi' - \text{id}|_{s-\sigma}}{1 - |\varphi' - \text{id}|_{s-\sigma}} \leq \frac{2n}{2n-1} \frac{|v|_s}{\sigma} \leq 2 \frac{|v|_s}{\sigma},$$

by triangular and Cauchy inequalities.

□

COROLLARY C.1.1 (Well definition of the operators ϕ). *For all s, σ*

– *if $g \in \mathcal{G}_{s+\sigma}^{\sigma/n}$, then $g^{-1} \in \mathcal{A}(\mathbb{T}_s^n, \mathbb{T}_{s+\sigma}^n)$*

– *if $g \in \mathcal{G}_{s+\sigma}^{\omega, \sigma^2/2n}$, then $g^{-1} \in \mathcal{A}(\mathbb{T}_s^n, \mathbb{T}_{s+\sigma}^n)$.*

As a consequence, the operators ϕ in (1.9), (2.2) and (2.10) are well defined.

PROOF. We recall the form of $g \in \mathcal{G}_{s+\sigma}^{\sigma/n}$:

$$g(\theta, r) = (\varphi(\theta), R_0(\theta) + R_1(\theta) \cdot r).$$

g^{-1} reads

$$g^{-1}(\theta, r) = (\phi^{-1}(\theta), R_1^{-1} \circ \varphi^{-1}(\theta) \cdot (r - R_0 \circ \varphi(\theta))).$$

Up to rescaling norms by a factor 1/2 like $\|x\|_s := \frac{1}{2}|x|$, the first statement is straightforward from theorem C.1. By abuse of notations, we keep on indicating $\|x\|_s$ with $|x|_s$.

Concerning those $g \in \mathcal{G}_{s+\sigma}^{\omega, \sigma^2/2n}$ we recall that g^{-1} is given by

$$g^{-1}(\theta, r) = (\varphi'^{-1}(\theta), {}^t\varphi' \circ \varphi^{-1}(\theta) \cdot r - \rho \circ \varphi^{-1}(\theta));$$

if $|\varphi^{-1} - \text{id}|_s < \sigma$ and $|\rho|_{s+\sigma} < \sigma/2$ with $|r \cdot \varphi' \circ \varphi^{-1}(\theta)|_s < \sigma/2$ we get the wanted thesis. Just note that

$$|{}^t(\varphi' - \text{id}) \cdot r|_s \leq \frac{n|r|_s}{\sigma} |\varphi - \text{id}|_{s+\sigma} \leq \sigma/2.$$

□

C.2. Calculus

Let E and F be two Banach spaces and U an open subset of E . Let $f : U \rightarrow F$ be a map. We say that f is differentiable at x if there exists a continuous linear map $L(x) : E \rightarrow F$ and a map φ defined for sufficiently small $\delta x \in E$ such that

$$f(x + \delta x) = f(x) + L(x) \cdot \delta x + \varphi(\delta x),$$

with

$$\lim_{\delta x \rightarrow 0} \frac{\varphi(\delta x)}{|\delta x|} = 0;$$

in other words φ is $o(\delta x)$ for $\delta x \rightarrow 0$.

It is clear that if f is differentiable at x then it is continuous at x ; moreover, if such a continuous linear map $L(x)$ exists, it is uniquely determined by f and x . We hence call it the derivative of f at x and indicate it with $f'(x)$.

Some useful derivations. Let now M be a differentiable manifold and $\text{Diff}^\infty(M)$ the group of smooth diffeomorphisms on it.

Inverse mapping.

LEMMA C.2.1. *Let ϕ be the map*

$$\phi : \text{Diff}^\infty(M) \rightarrow \text{Diff}^\infty(M), \quad f \mapsto f^{-1};$$

the derivative of ϕ at f in the direction of δf is given by

$$\phi'(f) \cdot \delta f = -(f'^{-1} \cdot \delta f) \circ f^{-1}.$$

PROOF. Let us write the identity $f \circ f^{-1} = \text{id}$. We compute $\delta(f \circ f^{-1})$ (shortcut for "the derivative of $f \circ f^{-1}$ with respect to f of increment δf "):

$$\begin{aligned} \delta(f \circ f^{-1}) &= 0 \\ \delta f \circ f^{-1} + f' \circ f^{-1} \cdot \delta f^{-1} &= 0, \end{aligned}$$

multiplying by $(f' \circ f^{-1})^{-1}$, we obtain $\delta f^{-1} = -(f'^{-1} \cdot \delta f) \circ f^{-1}$, hence the thesis. \square

Cotangent derivative. Let TM be the tangent bundle over M . Any diffeomorphism $g : TM \rightarrow TM$ lifts to a diffeomorphism $G : T^*M \rightarrow T^*M$ by

$$G(x, y) = (g(x), {}^t g'^{-1}(x) \cdot y).$$

Considering the map

$$\phi : \text{Diff}^\infty(M) \rightarrow \text{Diff}^\infty(T^*M), \quad g \mapsto {}^t g'^{-1}$$

from the previous lemma it follows that

$$\phi'(g) \cdot \delta g = -{}^t (g'^{-1})' \cdot (\delta g) \cdot g'^{-1}.$$

Push-forward of a vector field. Let u be a vector field on M and $g \in \text{Diff}^\infty(M)$. Define the map $\phi : g \mapsto g_*u$, we have

LEMMA C.2.2. *The derivative of ϕ at g of increment δg is given by*

$$\phi'(g) \cdot \delta g = [g_*u, \delta g \circ g^{-1}],$$

the bracket being the Lie brackets of vector fields.

PROOF. We want to evaluate the difference $(g + \delta g)_*u - g_*u$; we have the following equalities

$$\begin{aligned} (g + \delta g)_*u - g_*u &= ((\text{id} + \delta g \circ g^{-1}) \circ g)_*u - g_*u \\ &= (\text{id} + \delta g \circ g^{-1})_*g_*u - g_*u \\ &= (\text{id} + \delta g \circ g^{-1})' \cdot g_*u \circ (\text{id} + \delta g \circ g^{-1})^{-1} - g_*u \\ &= (\text{id} + \delta g \circ g^{-1})' \cdot g_*u \circ (\text{id} - \delta g \circ g^{-1}) - g_*u, \end{aligned}$$

making a Taylor expansion of $(\text{id} + \delta g \circ g^{-1})' \cdot g_*u$ at the identity we get

$$(g + \delta g)_*u - g_*u = (\delta g \circ g^{-1})' \cdot g_*u - (g_*u)' \cdot (\delta g \circ g^{-1}) + O(\delta g^2),$$

hence the thesis. \square

APPENDIX D

Some inequalities

D.1. Cauchy's Inequality

In 1831 Cauchy presented his Mémoire to the Accademia delle Scienze di Torino, in which he studied the equations of Hamilton; in this same Mémoire, he proved the famous formula

$$f(z) = \frac{1}{2\pi i} \int_{\gamma} \frac{f(\zeta)}{\zeta - z} d\zeta,$$

where f is a holomorphic function on some complex domain D and γ a positive-oriented circle in D , containing z . From this, we deduce that if $f \in \mathcal{A}(\mathbb{T}_{s+\sigma}^n, \mathbb{C})$, we have

$$|f'|_s \leq \frac{1}{\sigma} |f|_{s+\sigma},$$

defining $|f'|_s = \max_{\theta \in \mathbb{T}_s^n} \max_{|\zeta| \leq 1} |f'(\theta) \cdot \zeta|$.

Any differential operator of the first order satisfies a similar kind of inequality; in the case of our interest, we proved this for the defined L_α , $L_\alpha + A$ and $L_\alpha + [A, \cdot]$.

D.2. Lie brackets of vector fields

This is just an adaptation to vector fields on $\mathbb{T}_{s+\sigma}^n$ of the analogous lemma for vector fields on the torus \mathbb{T}_s^n in [Pös11].

LEMMA D.2.1. *Let f and g be two real analytic vector fields on $\mathbb{T}_{s+\sigma}^n$. The following inequality holds*

$$|[f, g]|_s \leq \frac{2}{\sigma} \left(1 + \frac{1}{e}\right) |f|_{s+\sigma} |g|_{s+\sigma}.$$

PROOF. Consider $f = (f^\theta, f^r) = \sum_{j=1}^n f^{\theta_j} \frac{\partial}{\partial \theta_j} + f^{r_j} \frac{\partial}{\partial r_j}$ and $g = (g^\theta, g^r) = \sum_{j=1}^n g^{\theta_j} \frac{\partial}{\partial \theta_j} + g^{r_j} \frac{\partial}{\partial r_j}$. From the definition of the Lie Brackets we have $[f, g] = \sum_k f(g^k) - g(f^k)$, where every component k reads

$$\begin{aligned} [f, g]^k &= \sum_{j=1}^n \left(f^{\theta_j} \frac{\partial g^k}{\partial \theta_j} + f^{r_j} \frac{\partial g^k}{\partial r_j} \right) - \left(g^{\theta_j} \frac{\partial f^k}{\partial \theta_j} + g^{r_j} \frac{\partial f^k}{\partial r_j} \right) \\ &= (Dg \cdot f - Df \cdot g)^k. \end{aligned}$$

We observe that for an holomorphic function $h : \mathbb{T}_{s+\sigma}^n \rightarrow \mathbb{C}$, one has

$$\left| \frac{\partial h}{\partial r_j} \right|_s = \sum_k \left| \frac{\partial h_k(r)}{\partial r_j} \right|_s e^{|k|s} \leq \sum_k \frac{1}{\sigma} |h_k(r)|_{s+\sigma} e^{|k|s} \leq \frac{1}{\sigma} |h|_{s+\sigma},$$

and

$$\begin{aligned} \left| \frac{\partial h}{\partial \theta_j} \right|_s &= \sum_k |k_j| |h_k(r)|_s e^{|k|s} \leq \sum_k |k| |h_k(r)|_s e^{|k|(s+\sigma)} e^{-|k|\sigma} \\ &\leq \frac{1}{e\sigma} \sum_k |h_k(r)|_{s+\sigma} e^{|k|(s+\sigma)} = \frac{1}{e\sigma} |h|_{s+\sigma}, \end{aligned}$$

where we bound $|k|e^{-|k|\sigma}$ with the maximum attained by xe^{-x} , $x > 0$, in $1/\sigma$, that is $1/e\sigma$. For the example we stressed the index "s" also in the notation of the Fourier's coefficient $|h_k|_s$ in order to stress where the supremum was taken.

Therefore, consider f and g in their Fourier's expansion, $Dg \cdot f$ read

$$Dg \cdot f = \sum_{k,\ell} ik \cdot f_\ell^\theta g_k e^{i(k+\ell)\theta} + D_r g_k \cdot f_\ell^r e^{i(k+\ell)\cdot\theta} = \sum_{k,\ell} ik \cdot f_{\ell-k}^\theta g_k e^{i\ell\cdot\theta} + D_r g_k \cdot f_{\ell-k}^r e^{i\ell\cdot\theta}.$$

Passing to norms we have the following inequality

$$\begin{aligned} |Dg \cdot f|_s &\leq \sum_{k,\ell} |k| |f_{\ell-k}^\theta| |g_k| e^{|k|s} e^{|\ell-k|s} + |D_r g_k| |f_{\ell-k}^r| e^{|k|s} e^{|\ell-k|s} \leq \\ &\leq \sum_{k,\ell} |k| |g_k| e^{-|k|\sigma} e^{|k|(s+\sigma)} |f_{\ell-k}^\theta| e^{|\ell-k|s} + |D_r g_k| e^{|k|s} |f_{\ell-k}^r| e^{|\ell-k|s} \\ &\leq \frac{1}{e\sigma} |g|_{s+\sigma} |f|_{s+\sigma} + \frac{1}{\sigma} |g|_{s+\sigma} |f|_{s+\sigma}, \end{aligned}$$

which follows from the previous remark. Hence the lemma. \square

Bibliography

- [AR67] R. Abraham and J. Robbin. Transversal mappings and flows. An appendix by Al Kelley. W. A. Benjamin, Inc., New York-Amsterdam, 1967.
- [Arn61] V. I. Arnold. Small denominators. I. Mapping the circle onto itself. Izv. Akad. Nauk SSSR Ser. Mat., 25:21–86, 1961.
- [Arn63] V. I. Arnold. Proof of a theorem of A. N. Kolmogorov on the invariance of quasi-periodic motions under small perturbations of the Hamiltonian. Usp. Mat. Nauk SSSR, 18(13), 1963.
- [Arn88] V.I. Arnold. Dynamical Systems III, volume 3 of Encyclopedia of Mathematical Science. Springer, Heidelberg, 1988.
- [BHTB90] H. W. Broer, G. B. Huitema, F. Takens, and B. L. J. Braaksma. Unfoldings and bifurcations of quasi-periodic tori. Mem. Amer. Math. Soc., 83(421):viii+175, 1990.
- [Bos85] J.-B. Bost. Tores invariants des systèmes dynamiques hamiltoniens [d’après Kolmogorov, Arnold, Moser, Rüssmann, Zender, Herman, Pöschel, ...]. Number 639 in Séminaires BOURBAKI, pages 113–157, 1985.
- [Cas15] T. Castan. Application of KAM theory to the planar 3-body problem. *Ph.D thesis*, in preparation, 2015.
- [CC09] A. Celletti and L. Chierchia. Quasi-periodic attractors in celestial mechanics. Arch. Rational Mech. Anal., (191):311–345, 2009.
- [Cha10] C. Chavaudret. Réductibilité des cocycles quasi-périodiques. *Ph.D thesis*, 2010.
- [Che85a] A. Chenciner. Bifurcations de points fixes elliptiques. I. Courbes invariantes. Inst. Hautes Études Sci. Publ. Math., 61:67–127, 1985.
- [Che85b] A. Chenciner. Bifurcations de points fixes elliptiques. II. Orbites périodiques et ensembles de Cantor invariants. Invent. Math., 80(1):81–106, 1985.
- [Che88] A. Chenciner. Bifurcations de points fixes elliptiques. III. Orbites périodiques de “petites” périodes et élimination résonnante des couples de courbes invariantes. Inst. Hautes Études Sci. Publ. Math., 66:5–91, 1988.

- [Chi03] L. Chierchia. KAM lectures. In Dynamical systems. Part I, Publ. Cent. Ric. Mat. Ennio Giorgi, pages 1–55. Scuola Norm. Sup., Pisa, 2003.
- [CR13] A. C. M. Correia and P. Robutel. Spin-Orbit Coupling and Chaotic Rotation for Coorbital Bodies in Quasi-circular Orbits. The Astrophysical Journal, 779:20, December 2013.
- [DLCB12] J.-B. Delisle, J. Laskar, A. C. M. Correia, and G. Boué. Dissipation in planar resonant planetary systems. Astronomy & Astrophysics, 546:A71, October 2012.
- [Féj04] J. Féjoz. Démonstration du "théorème d'Arnold" sur la stabilité du système planétaire (d'après Michael Herman). Michael Herman Memorial Issue, Ergodic Theory Dyn. Syst., (24:5):1521–1582, 2004.
- [Féj10] J. Féjoz. Mouvements périodiques et quasi-périodiques dans le problème des n corps, *mémoire d'habilitation à diriger des recherches*, 2010.
- [Féj12] J. Féjoz. A proof of the invariant torus theorem of Kolmogorov. Regul. Chaotic Dyn., 17(1):1–5, 2012.
- [FG02] K. Fritzsche and H. Grauert. From holomorphic functions to complex manifolds, volume 213 of Graduate Texts in Mathematics. Springer-Verlag, New York, 2002.
- [FK09] B. Fayad and R. Krikorian. Herman's last geometric theorem. Ann. Sci. Éc. Norm. Supér. (4), 42(2):193–219, 2009.
- [Gio03] A. Giorgilli. Exponential stability of Hamiltonian systems. In Dynamical systems. Part I, Publ. Cent. Ric. Mat. Ennio Giorgi, pages 87–198. Scuola Norm. Sup., Pisa, 2003.
- [GP66] P. Goldreich and S. Peale. Spin-orbit coupling in the solar system. The Astronomical Journal, 71:425, August 1966.
- [Ham82] R. Hamilton. The implicit function theorem of Nash and Moser. Bull. A. M. S., 7(1):65–222, 1982.
- [Her83] M.-R. Herman. Sur les courbes invariantes par les difféomorphismes de l'anneau. Vol. 1, volume 103 of Astérisque. Société Mathématique de France, Paris, 1983. With an appendix by Albert Fathi, With an English summary.
- [Jac72] H. Jacobowitz. Implicit function theorems and isometric embeddings. Ann. of Math. (2), 95:191–225, 1972.
- [Las10] J. Laskar. Dynamique du Système Solaire. Mouvements réguliers et chaotiques. Notes d'un cours à l'Observatoire de Paris, 2010.
- [Mey75] K. R. Meyer. The implicit function theorem and analytic differential equations. In Dynamical systems—Warwick 1974

- (Proc. Sympos. Appl. Topology and Dynamical Systems, Univ. Warwick, Coventry, 1973/1974; presented to E. C. Zeeman on his fiftieth birthday), pages 191–208. Lecture Notes in Math., Vol. 468. Springer, Berlin, 1975.
- [Mos62] J. Moser. On invariant curves of area-preserving mappings of an annulus. Nachr. Akad. Wiss. Göttingen Math.-Phys. Kl. II, 1962:1–20, 1962.
- [Mos67] J. Moser. Convergent series expansions for quasi-periodic motions. Math. Annalen, (169):136–176, 1967.
- [New71] I. Newton. Philosophiae naturalis principia mathematica. Macleose, 1871.
- [Pös89] J. Pöschel. On elliptic lower-dimensional tori in Hamiltonian systems. Math. Z., 202(4):559–608, 1989.
- [Pös01] J. Pöschel. A lecture on the classical KAM theorem. In Smooth ergodic theory and its applications (Seattle, WA, 1999), volume 69 of Proc. Sympos. Pure Math., pages 707–732. Amer. Math. Soc., Providence, RI, 2001.
- [Pös11] J. Pöschel. KAM à la R. Regul. Chaotic Dyn., 16(1-2):17–23, 2011.
- [Rüs70] H. Rüssmann. Kleine Nenner. I. Über invariante Kurven differenzierbarer Abbildungen eines Kreisringes. Nachr. Akad. Wiss. Göttingen Math.-Phys. Kl. II, 1970:67–105, 1970.
- [Rüs75] H. Rüssmann. On optimal estimates for the solutions of linear partial differential equations of first order with constant coefficients on the torus. In Dynamical systems, theory and applications (Rencontres, Battelle Res. Inst., Seattle, Wash., 1974), pages 598–624. Lecture Notes in Phys., Vol. 38. Springer, Berlin, 1975.
- [Rüs76] H. Rüssmann. On optimal estimates for the solutions of linear difference equations on the circle. In Proceedings of the Fifth Conference on Mathematical Methods in Celestial Mechanics (Oberwolfach, 1975), Part I, volume 14, pages 33–37, 1976.
- [Sev99] M. B. Sevryuk. The lack-of-parameters problem in the KAM theory revisited. In Hamiltonian systems with three or more degrees of freedom (S’Agaró, 1995), volume 533 of NATO Adv. Sci. Inst. Ser. C Math. Phys. Sci., pages 568–572. Kluwer Acad. Publ., Dordrecht, 1999.
- [Sev03] Mikhail B. Sevryuk. The classical KAM theory at the dawn of the twenty-first century. Mosc. Math. J., 3(3):1113–1144, 1201–1202, 2003. {Dedicated to Vladimir Igorevich Arnold on the occasion

- of his 65th birthday}.
- [Sev06] M. B. Sevryuk. Partial preservation of frequencies in KAM theory. *Nonlinearity*, 19(5):1099–1140, 2006.
 - [Shu78] Michael Shub. *Stabilité globale des systèmes dynamiques*, volume 56 of *Astérisque*. Société Mathématique de France, Paris, 1978. With an English preface and summary.
 - [Shu87] Michael Shub. *Global stability of dynamical systems*. Springer-Verlag, New York, 1987. With the collaboration of Albert Fathi and Rémi Langevin, Translated from the French by Joseph Christy.
 - [SL12] L. Stefanelli and U. Locatelli. Kolmogorov’s normal form for equations of motion with dissipative effects. *Discrete Contin. Dyn. Syst. Ser. B*, 17(7):2561–2593, 2012.
 - [Wag10] F. Wagener. A parametrised version of Moser’s modifying terms theorem. *Discrete Contin. Dyn. Syst. Ser. S*, 3(4):719–768, 2010.
 - [Yoc92] J-C. Yoccoz. Travaux de Herman sur les tores invariants. *Astérisque*, (206):Exp. No. 754, 4, 311–344, 1992. Séminaire Bourbaki, Vol. 1991/92.
 - [Zeh75] E. Zehnder. Generalized implicit function theorem with applications to some small divisor problems, i. XXVIII:91–140, 1975.
 - [Zeh76] E. Zehnder. Generalized implicit function theorem with applications to some small divisor problems, ii. XXIX:49–111, 1976.